

SMART HJC

11Be

Bluetooth Communication System
For HJC HELMETS



User Guide
English / Version 1.0.0



Table of Contents

| | | |
|----------|--|-----------|
| 1 | Product at a glance | 5 |
| 1.1 | SMART HJC 11Be Package Contents | 5 |
| 1.2 | Product Details | 6 |
| 2 | Installing 11Be on your helmet | 7 |
| 2.1 | Removing the left / right helmet module covers | 7 |
| 2.2 | Removing the Helmet Rear Module Cover | 7 |
| 2.3 | Detaching the Helmet Chick Pad | 7 |
| 2.4 | Installing the BMS module | 8 |
| 2.5 | Installing the Bluetooth Module | 9 |
| 2.6 | Boom Microphone Installation for Open Face Helmets and System Helmets | 10 |
| 2.7 | Installing a wired velcro microphone and left speaker for a full face helmet | 11 |
| 2.8 | Installing the right speaker | 12 |
| 3 | Getting started with 11Be | 13 |
| 3.1 | Turn on the device | 13 |
| 3.2 | Power off the device | 13 |
| 3.3 | Automatic phone pairing | 13 |
| 4 | Power - Standby & Charging & External Battery | 14 |
| 4.1 | Bluetooth module enters standby mode | 14 |
| 4.2 | Charging the product | 14 |
| 4.3 | External battery (when charging) operation | 14 |
| 4.4 | Bluetooth Factory Reset | 14 |
| 5 | Change your device's voice guidance using the mobile app | 15 |
| 6 | Update firmware using the mobile app | 16 |
| 7 | Battery charging step guide | 17 |
| 8 | Using the phone function & volume control function | 18 |

Table of Contents

| | | |
|-----------|--|-----------|
| 9 | Using the music listening function | 18 |
| 10 | Start pairing your phone in Bluetooth setting mode | 19 |
| | 10.1 Start / end Bluetooth setting mode | 19 |
| | 10.2 Pairing your phone in Bluetooth setting mode | 19 |
| 11 | Start intercom pairing in Bluetooth setting mode | 20 |
| | 11.1 Start intercom pairing in Bluetooth setting mode | 20 |
| 12 | Connecting to an intercom with a friend | 21 |
| | 12.1 Pairing Device 1 Intercom Connection | 21 |
| | 12.2 Pairing Device 2 Intercom Connection | 21 |
| | 12.3 Pairing 3rd device Intercom connection | 21 |
| 13 | SMART HJC Connecting intercom with other devices | 22 |
| | 13.1 Running SMART HJC (50B / 21B / 11B) Universal Intercom Pairing Mode | 22 |
| | 13.2 Running SMART HJC (11Be) intercom pairing mode | 22 |
| 14 | Download the smartphone mobile app | 23 |
| | 14.1 Download our dedicated mobile app | 23 |
| | 14.2 Mobile App OTA (Over-The-Air) | 23 |
| 15 | Getting started with the mobile app 1 | 24 |
| 16 | Getting started with the mobile app 2 | 25 |
| | 16.1 Power on | 25 |
| | 16.2 Power off | 25 |
| | 16.3 Automatic phone pairing | 25 |
| | 16.4 Bluetooth Setting > Phone Pairing | 25 |

Table of Contents

| | | |
|-----------|---|-----------|
| 17 | Getting started with the mobile app 3 | 26 |
| | 17.1 Bluetooth Setting > Intercom Pairing [Connecting Intercom Friends] | 26 |
| | 17.2 Start/end intercom call | 26 |
| 18 | Function mode selection | 27 |
| 19 | Bluetooth main | 28 |
| 20 | Pairing status | 29 |
| 21 | Bluetooth audio settings | 30 |
| 22 | Bluetooth update | 31 |
| 23 | Authentication information | 32 |

SMART HJC 11Be Package Contents



SMART HJC 11Be

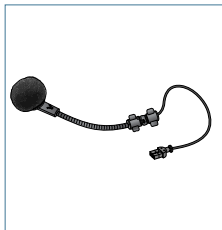

Wired boom microphone
for modular/open face helmets



Wired Microphone
for Full Face Helmet

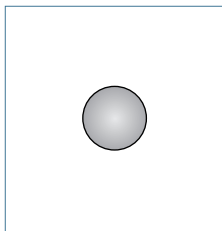

Velcro tape for wired microphone
(supplied attached)

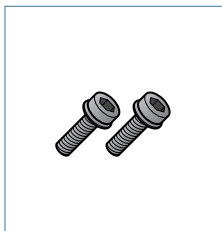

Screw

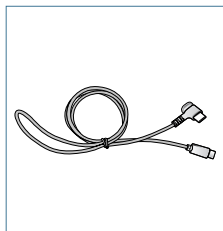

USB Power Charging Cable
(USB C to C)

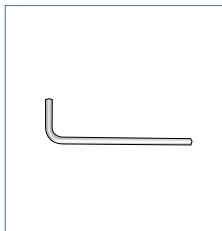

Hex wrench

Product Details

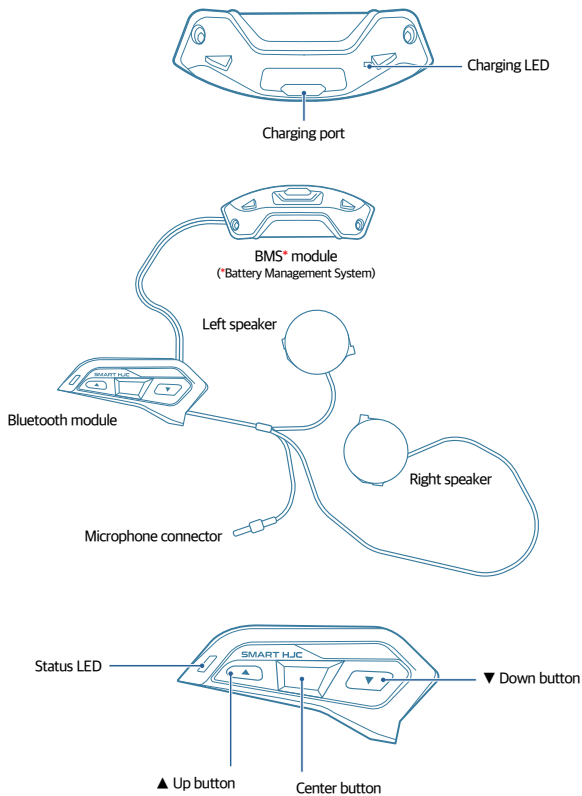

Installing 11Be on your helmet

Removing the left / right helmet module covers

Press the fixing levers on the left/right covers and slide them at an angle as shown in the figure below to separate them.

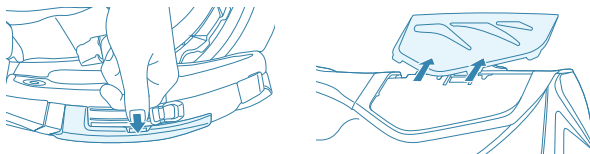

Removing the Helmet Rear Module Cover

Using the provided Allen wrench, loosen the two short screws on the rear cover of the helmet and remove the cover.

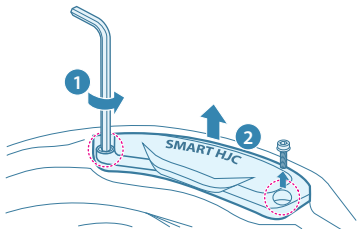

Detaching the Helmet Chick Pad

Remove the cheek pads from the helmet by removing the snap fasteners attached to the cheek pads.

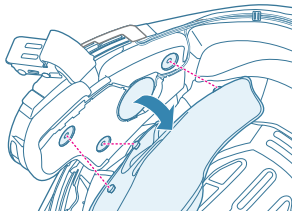

Installing the BMS module

1. Place the USB port of the BMS module facing the bottom of the helmet, pull up the rubber guard, and then insert the BMS module. Insert it into the slot.

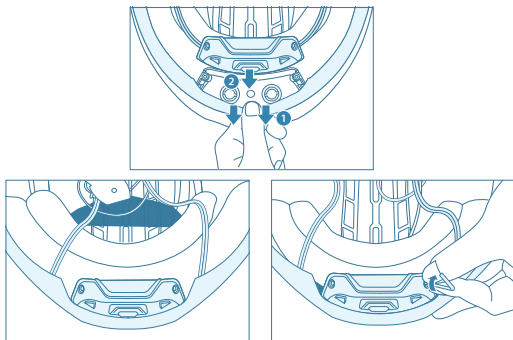

2. Use the included wrench bolts and wrench driver to secure the module to the helmet.

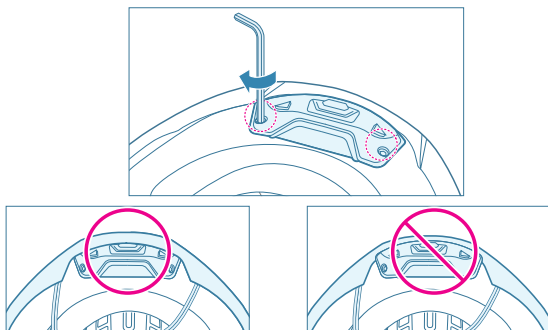

NOTICE

Make sure the rubber guard on the helmet is not caught between the BMS module and the slot.

Installing the Bluetooth Module

1. Check the fixing parts of the upper picture **1** and lower picture **2** of the Bluetooth module.
2. Position it in the module fixing groove of the helmet as shown in Figure **3** and push it in the direction of the arrow until you hear a click.
3. Look at the bottom of the helmet and check if it is properly installed. (Figure **4** Arrow)

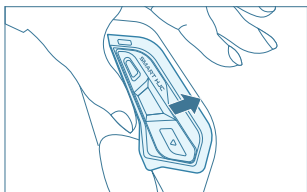
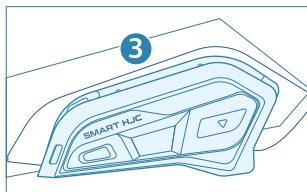
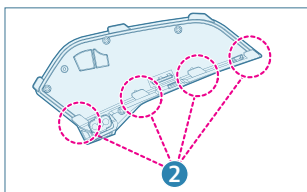
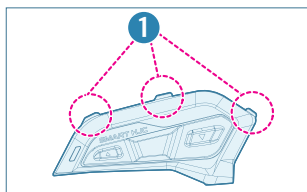

Boom Microphone Installation for Open Face Helmets and System Helmets

1. Position the boom microphone mounting lug into the groove on the helmet EPS.
2. Insert the long fixing protrusion first, then insert the short fixing protrusion to complete the fixation.

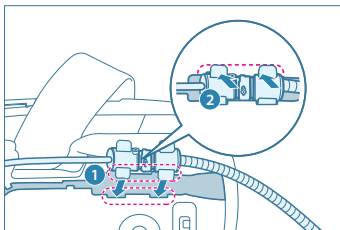

3. Secure the microphone wire into the helmet EPS groove and insert the remaining wire into the groove for installing the speaker unit.

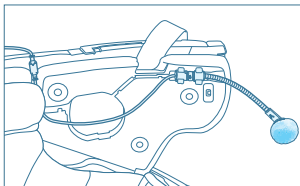
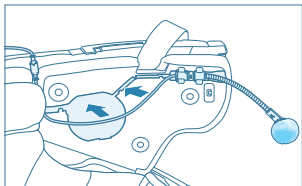

When installing the microphone direction speaker unit, place the remaining microphone wire under the long speaker fixing groove, install the speaker fixing protrusion into the helmet EPS fixing groove, and then connect it to the Bluetooth module microphone connector.

NOTICE

When installing, make sure that the microphone wire does not press on the speaker unit.

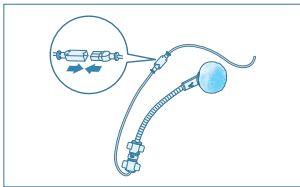
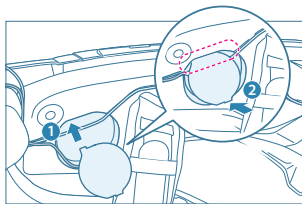

Installing a wired velcro microphone and left speaker for a full face helmet

1. Remove the adhesive tape cover of the included microphone Velcro, attach it to the inside of the helmet's chin guard, and then attach the wired microphone to the Velcro tape.

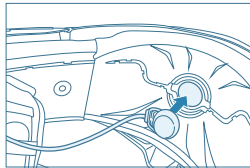
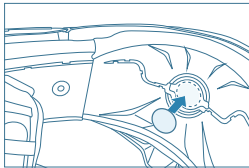
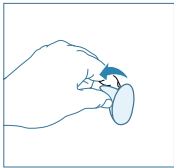

2. Secure the microphone wire into the helmet EPS groove and insert the remaining wire into the groove for installing the speaker unit.

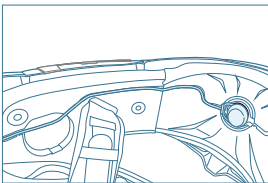
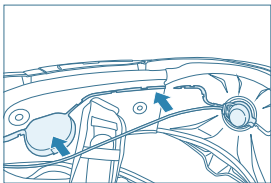

3. When installing the left speaker unit, place the remaining microphone wire under the long speaker fixing groove, install the speaker fixing protrusion into the helmet EPS fixing groove, and then connect it to the Bluetooth module microphone connector.

NOTICE

When installing, make sure that the microphone wire does not press on the speaker unit.

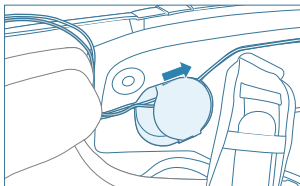
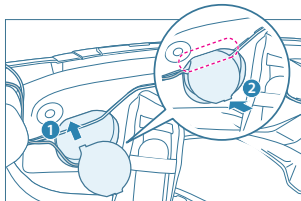

4. Refer to the microphone connector connection diagram on the previous page.

Installing the right speaker

1. Remove the two snap fasteners from the ceiling lining on the rear of the helmet.
2. Pass the right speaker and wire through the inside of the helmet ceiling lining.
3. First insert the long fixing protrusion of the right speaker into the fixing groove toward the bottom of the helmet, then insert the short fixing protrusion into the upper part of the helmet. Please insert it into the direction fixing groove.
4. Secure one snap fastener on the right side of the ceiling lining on the back of the helmet, then organize the wiring and secure the remaining one.

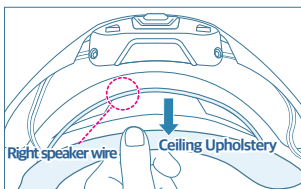
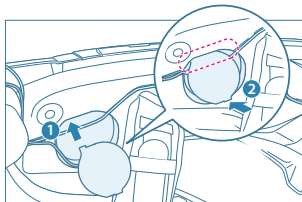
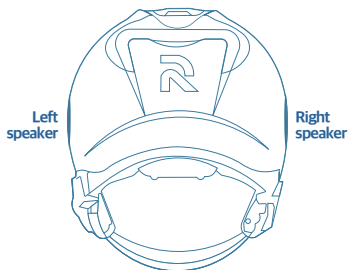
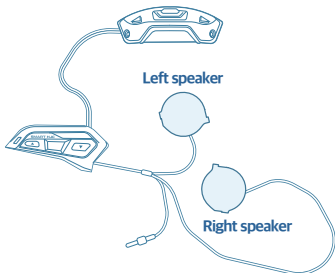

Getting started with 11Be

Turn on the device

Press the ▲ Up button and the Center button on the device simultaneously for 1.5 seconds until you hear a beep. The Power On announcement will be heard and the device will start.

Power off the device

With the device powered on, press and hold the ▲ Up button and the Center button simultaneously for 1.5 seconds until you hear a beep. The Power Off announcement will be played and the device will be turned off.

Automatic phone pairing

When you turn on the device after purchasing it for the first time, it will automatically enter phone pairing mode. Search for the device using the Bluetooth search bar in the phone settings menu and connect it. (Double-pressing the ▼ down button while in phone pairing mode will exit the mode.)

Bluetooth LED

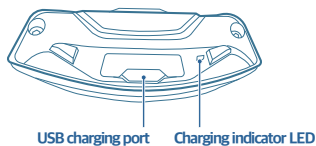
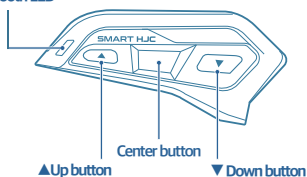



| mode | Key actions | Bluetooth LED | Voice guidance | Beep sound |
|---------------|---------------------------------------|-----------------|----------------|------------|
| Power On | ▲ + Center (press for 1.5 seconds) | | Power on | Beep x 1 |
| Power off | ▲ + Center (press for 1.5 seconds) | | Power off | Beep x 1 |
| Phone pairing | | Cyclic flashing | Phone Pairing | - |

Power - Standby & Charging & External Battery

Bluetooth module enters standby mode

1. After 5 minutes of disconnection between Bluetooth and smartphone, the Bluetooth module will automatically power off. At this time, even if the EDR CAM is recording, the EDR CAM and Bluetooth module will stop operating and power off.
2. To use the Bluetooth module again, turn it on and reconnect it to your smartphone via Bluetooth.

Charging the product

1. Charges from a 5V input USB charging device and supports USB-C type connector.
2. The LED lights up () when the product is charging / () when fully charged.
3. Please turn off the product to charge. (For safety, battery charging is not supported while the product is in operation.)

External battery (when charging) operation

When an external battery is connected, the product operation is supported, and the BMS LED lights up ().

(For safety, the smart charge monitor function* operates when the product is in operation.)

*Smart charging monitor function

This feature maintains the device battery level when the external battery is connected, preventing overcharging and power waste. It works while the external battery is connected, and the feature is automatically turned off when the external battery is removed.

Bluetooth Factory Reset

It will be initialized to the settings when purchasing the product.

(Press the Center button for 10 seconds)

Change your device's voice guidance using the mobile app

When shipped from the factory, the device's voice guidance is set to English. You can change the language of your desired device using the mobile app.

NOTICE

1. This function can be performed only when the smartphone and device are connected via Bluetooth.
2. This function can be performed only when the device is powered on or has battery level 3 or higher.
3. Do not turn off the device or unplug the power cable during downloading and updating. This may cause malfunction.



In the Change Page window, tap the Update button.

Please select your preferred language. After the download is complete on your device, your device will restart.

Supported languages : Korean / English / French / German / Italian / Spanish

Update firmware using the mobile app

You can update Bluetooth firmware using the mobile app.

If the firmware included in the mobile app and the firmware version of the device are different, a firmware update message will be displayed on the mobile app Bluetooth main screen and update screen.

(However, if the firmware of the device is the latest version, the update request will not be displayed.)

NOTICE

1. Update your mobile app to keep the latest firmware.
2. This function can be performed only when the smartphone and device are connected via Bluetooth.
3. This function can be performed only when the device is powered on or has battery level 3 or higher.
4. Do not turn off the device or unplug the power cable during downloading and updating.
This may cause malfunction.



Firmware update status

Tap the Update button in the Change Page window.



Tap the Firmware Update button. Once the download and update are complete, your device will automatically restart.

Battery charging step guide

The battery charge status is divided into 4 levels from level 0. The charge status is displayed on the connected mobile app, and if charging is required, a charging warning voice guidance sound is heard when the device starts.



Bluetooth charging status guide

| Level | Bluetooth charging status | Voice guidance |
|--------|---------------------------|----------------|
| Step 0 | Charging warning | BT Low Battery |
| Step 1 | normal | - |
| Step 2 | Fully charged | - |
| Step 3 | | |
| Step 4 | | |

Using the phone function & volume control function

| Mode | Key actions | Bluetooth LED | Voice guidance | Beep Sound |
|---------------------------|-----------------------|---------------|----------------|------------|
| The phone rings | - | Flashing | - | - |
| Answer the phone | Center (press once) | Flashing | - | Beep x 1 |
| Reject the call | Center (double press) | Flashing | - | Beep x 1 |
| Hang up [during a call] - | Center (double press) | Flashing | - | Beep x 1 |
| Headset volume up | ▲ (press once) | | - | Beep x 1 |
| Headset volume down | ▼ (press once) | | - | Beep x 1 |

Volume up (press once)

Volume down (press once)

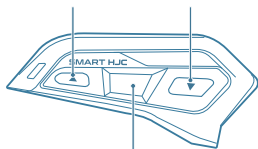

Answer a call (press once)
Reject call (double press)
Hang up (double press)

Play music (hold for 1 second)
Pause music (hold for 1 second)

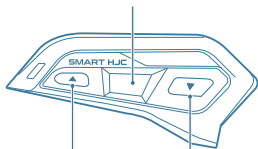

Next song (hold for 1 second)
Previous song (hold for 1 second)

Using the music listening function

| mode | Key actions | Bluetooth LED | Voice guidance | Beep Sound |
|---------------|-----------------------------|---------------|----------------|------------|
| Play music | Center (press for 1 second) | Flashing | - | Beep x 1 |
| Music stop | Center (press for 1 second) | Flashing | - | Beep x 1 |
| Next Song | ▲ (press for 1 second) | Flashing | - | Beep x 1 |
| Previous Song | ▼ (press for 1 second) | Flashing | - | Beep x 1 |

Start pairing your phone in Bluetooth setting mode

Phone pairing and intercom pairing can be performed in Bluetooth setting mode.

Start / end Bluetooth setting mode

▼ Press the down button and the Center button simultaneously for 1 second to enter “Bluetooth setting mode”.

1. Double-pressing the [Center button] during Bluetooth setting mode will stop the mode.
2. Once the pairing settings are complete, the Bluetooth setting mode will automatically end.
3. If pairing settings are not completed in Bluetooth setting mode, the mode will automatically end after 10 seconds.

Pairing your phone in Bluetooth setting mode

In Bluetooth setting mode, pressing the ▼ down button once will start a new “Phone Pairing”. Existing phone pairing will be reset, and the status will be displayed through a guidance announcement and LED. (See pairing status table below)

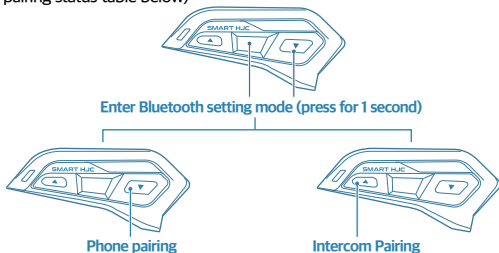

| mode | Key actions | Bluetooth LED | Voice guidance | Beep sound |
|-------------------------|-------------------------------|--------------------|------------------|------------|
| Bluetooth setting mode | ▼+Center (press for 1 second) | /// | BT Setting | Beep x1 |
| Bluetooth settings out | Center (double press) | /// | - | Beep x2 |
| Phone pairing | ▼ (press once) | ///Cyclic flashing | Phone Pairing | - |
| Intercom Pairing * | ▲ (press once) | ///Cyclic flashing | Intercom Pairing | - |
| Cancel phone pairing | ▼ (double press) | /// | Pairing Canceled | - |
| Cancel intercom pairing | ▲ (double press) | /// | Pairing Canceled | - |

Intercom Pairing * : How to connect and use intercom with a paired friend is on page 20.

Start intercom pairing in Bluetooth setting mode

Start intercom pairing in Bluetooth setting mode

When you and your friend's device initiate the pairing action together, the devices will automatically pair and connect. After pairing, you can make intercom calls.

1. Enter Bluetooth settings.
2. In the Bluetooth settings, press the ▲ Up button once. The status is displayed with a guidance message and LED. (Refer to the pairing status table above)
3. The device can pair with up to 3 friends and remembers pairing information even when the device is turned off.
4. If you register a second friend pairing while the first friend is registered,
 - The first registered pairing device becomes device 2, and the second registered friend becomes device 1.
 - Likewise, when a third friend is registered for pairing, the third registered friend becomes device number 1.
 - The friend who registered second will have device number 2, and the friend who registered first will have device number 3.

NOTICE

1. To connect to an intercom, you must perform the following actions with your friend's device at close range.
2. Intercom pairing allows up to 3 friends to be registered, and intercom communication is only possible 1:1.

Connecting to an intercom with a friend

Friends registered for intercom pairing on the device will have their registration information saved in the device even when the device is turned off. Turn on the device and use it by following the connection order below with the registered friend.

Pairing Device 1 Intercom Connection

1. Press the [Center button] once on the device you want to connect to enter the intercom connection mode. You will hear a dial tone from the device.
2. The intercom receiving device will be notified with a receiving tone, and the recipient will complete the intercom connection and begin the call by pressing the Center button once.
3. During an intercom call, double-press the [Center button] to end the intercom call.

Pairing Device 2 Intercom Connection

Double-tap the [Center button] on the device you want to connect to enter the intercom connection mode. The process for connecting devices is the same as connecting to intercom on device 1.

Pairing 3rd device Intercom connection

Press the [Center button] three times on the device you want to connect to enter the intercom connection mode. The process for connecting devices is the same as connecting to intercom on device 1.

The last paired device becomes device 1, and connection information is saved in reverse order.

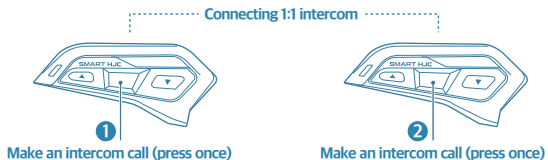

SMART HJC Connecting intercom with other devices

SMART HJC Connecting intercom with other devices

You can make an intercom connection with (11Be) product by switching the setting of SMART HJC (50B / 21B / 11B) product to Universal Intercom Pairing Mode. You can also make an intercom connection with SMART HJC (10B / 20B) and SENA product through the Universal Mode setting.

NOTICE

Connection is possible if the SMART HJC Bluetooth headset supports Bluetooth HFP (Hands-Free Profile).

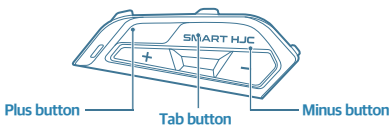

SMART HJC (50B / 21B / 11B) UI Department

Running SMART HJC (50B / 21B / 11B) Universal Intercom Pairing Mode

1. Press and hold the tab button for 10 seconds [Settings menu announcement will be played]
2. Press the minus button 3 times [Universal intercom pairing guidance announcement will be heard]
3. Press the tab button once [Enter universal intercom pairing mode]

Running SMART HJC (11Be) intercom pairing mode

1. Press the Center button and the ▼ down button simultaneously to enter the “Bluetooth Settings” mode.
2. In “Bluetooth Setting” mode, press the ▲ Up button to enter intercom pairing mode.

When SMART HJC (50B / 21B / 11B) and (11Be) devices enter pairing mode at the same time, an intercom connection is automatically established and calls are possible.

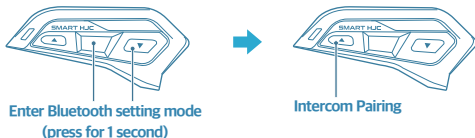

SMART HJC (11Be) UI section

Download the smartphone mobile app

Download our dedicated mobile app

Search for “SMART HJC BT (11BC / 11Be)” in “Google Play Store” for Android phones or “App Store” for iPhones, or download the mobile app using the QR code below.



Android AOS
Google Play Store



Apple IOS
App Store



Mobile App OTA (Over-The-Air)

1. You can download the latest firmware via Bluetooth OTA function.
2. You can download multiple voice guidance languages via the Bluetooth OTA function.

NOTICE

For continuous quality improvement, device performance improvements and function updates may be made without prior notice.

Getting started with the mobile app 1

1. Download and install the mobile app from the App Store.
2. Pair the device in your smartphone's Bluetooth settings.
3. Tap the installed app icon to launch the app.
4. When the pairing pop-up appears while running the app, select "Pair" to connect to the Bluetooth device.

NOTICE

1. If iOS (Apple) users fail to connect the app to a Bluetooth device, press the 'Reconnect' button on the app standby screen to try pairing again.
2. AOS (Android) users will automatically be taken to the Bluetooth main screen without a pairing request pop-up within the app after completing device pairing in the smartphone Bluetooth settings.



Getting started with the mobile app 2



Power on

Press and hold the ▲ (Up) button and the center button on the device simultaneously for 1.5 seconds until you hear a beep. You will hear the voice guidance "Power on" and the device will start.

Power off

With the device powered on, press and hold the ▲ (Up) button and the center button simultaneously for 1.5 seconds until you hear a beep. You will hear a voice prompt saying "Power off" and the device will shut down.

Automatic phone pairing

When you first purchase the device and turn it on, it automatically enters phone pairing mode.

Search for the device in your smartphone's Bluetooth settings and connect it.

(If you press the ▼ (down) button twice during phone pairing mode, the mode will be stopped.)



Bluetooth setting > Phone pairing

STEP 1

After turning on the power, press the center button + ▼ (down) button simultaneously for 1 second. The device will enter Bluetooth setting mode with a beep sound, and the "Bluetooth setting" voice guidance will begin.

STEP 2

In Bluetooth settings mode, pressing the ▼ (down) button once initiates "Phone Pairing."

The existing connection will be automatically disconnected, and the newly paired device will connect to your phone.

Cancel phone pairing

In phone pairing mode, double-tapping the ▼ (down) button will switch to "Cancel Pairing" mode. Then, re-select the device in your smartphone's Bluetooth settings.

Getting Started with the Mobile App 3



Bluetooth Setting > Intercom Pairing [Connecting Intercom Friends]

STEP 1

After powering on both devices, simultaneously press and hold the center button and the ▼ (down) button on each device for 1 second. Once you hear a beep and enter Bluetooth setup mode, press the ▲ (up) button on each device once. You will hear the voice prompt "Intercom Pairing." Repeated beeps will indicate the pairing process, and the other device will automatically search for the other device.

STEP 2

After the "Intercom Pairing" voice guidance, the two devices will automatically connect to intercom communication.

Cancel intercom pairing

In intercom pairing mode, pressing the ▲ (Up) button twice will switch to "Cancel Pairing" mode.



Start/end intercom call

To call back to a recently paired friend, press the center button once.

The intercom will automatically connect with a beep sound from both devices.

During an intercom call, if either the recipient or the caller double-presses the center button, the intercom connection will end.

NOTE

1. You can register up to 3 friends for intercom. How to intercom with 3 friends Please refer to page 21 of the User Guide.
2. Intercom friend registration is only successful when the two devices are in close proximity to each other.

Function mode selection

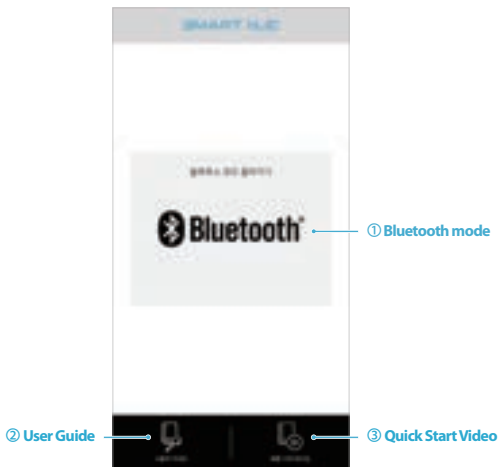

① Select Bluetooth mode

Once the device and mobile app are paired, you will see a button to enter the Bluetooth main screen.

② User Guide

You can view the user manual.

③ Quick Start Video

You can see a video of it being mounted on a helmet.

Bluetooth main

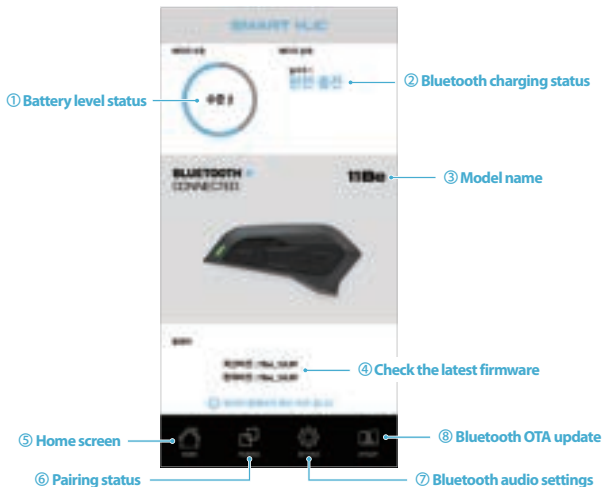

① Battery level status

② Bluetooth charging

③ Model name

④ Check the latest firmware

If your device's firmware is not up to date, a red warning message will appear.

⑤ Home screen

Go to the Function Mode Selection screen.

⑥ Pairing status

You can check the Bluetooth and intercom pairing status and edit the name of the paired device.

⑦ Bluetooth audio settings

You can change your Bluetooth audio settings.

⑧ Bluetooth OTA update

You can update the Bluetooth firmware and change and update the voice guidance language of your device.

Pairing status

① List of mobile phones connected to my device

② List of intercoms connected to my device

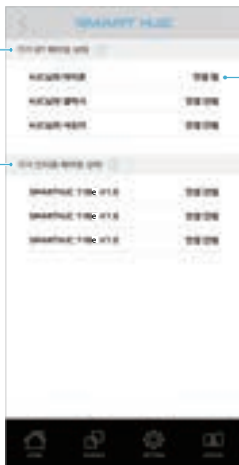

Pairing status

① List of phones connected to my device

A list of phones currently connected to my device via Bluetooth will be displayed. When connecting for the first time, the phone's unique Bluetooth number will be displayed. Tap that number to change the name, making it easier to identify the device.

② List of intercoms connected to my device

A list of intercom devices currently connected to your device will be displayed. When connecting for the first time, the device's unique Bluetooth number will be displayed. Tap that number to change the name, making it easier to identify the device.

Bluetooth audio settings

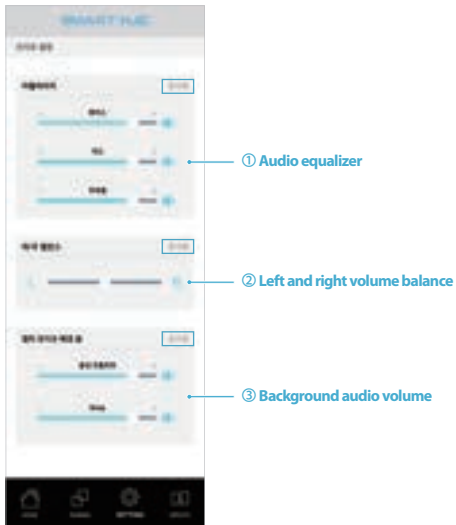

NOTE

1. After adjusting the audio on the device, the settings will remain even if you turn the device off and then on again.
2. Selecting Reset will return all settings on the device to their factory settings.

Bluetooth update



① Bluetooth firmware update required

When the mobile app is connected to your device, it automatically checks for updates and notifies you.

② Bluetooth latest firmware status

If your device is using the latest firmware, the app will display "Your device's firmware is the latest version" and you can use it without a separate update.

③ Download and change the voice guidance language of your device.

The device is factory-set to English voice guidance. You can easily change the language of your device's voice guidance by selecting and downloading your preferred language through the mobile app.

NOTE

1. Always keep your mobile app up to date. The latest app can reliably manage and update your device's firmware.
2. The update will not proceed if your device's battery is not sufficiently charged. Please check the battery level before updating.
3. If you connected the power cable before the update, never disconnect it during the update. This may cause device errors.
4. Once the update is complete, your device will automatically restart.

English

SMART HJC 11BC

KC Certification Information



Certification Number : R-R-M2v-11Be

Product Name : Bluetooth for motorcycle helmets

Model Name : 11Be

Manufacturer/Country of Origin : MtekVision Co., Ltd. / Korea

Distributor : HJC Corporation Cp., Led.

Domestic and international certification information



CE
(EU)



UKC
(UK)



FCC
(USA)



IC
(CAN)



KC
(KOR)

HJC Corporation

HJC Bldg, 1002, Yangjae-daero, Songpa-gu,
Seoul, 05708 Seoul, Republic of Korea
www.hjchelmets.com



HJC Europe

1 Rue BENJAMIN SILLIMAN JR, 67116
REICHSSTETT, FRANCE

Manufacturer

MtekVision Co., Ltd.
Room 333, 42, Changeop-ro, Sujeong-gu,
Seongnam-si, Gyeonggi-do, Republic of Korea
www.mtekvision.com

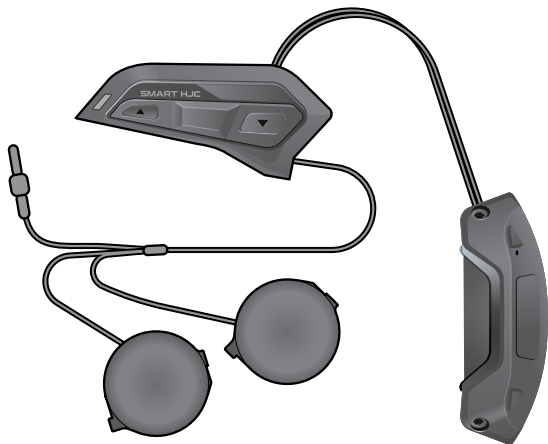

SMART HJC

11Be

Système de communication Bluetooth pour les casques HJC



Guide de l'utilisateur
Français/Version 1.0.0



Table des matières

| | | |
|----------|---|-----------|
| 1 | Aperçu des produits | 5 |
| 1.1 | Contenu du package SMART HJC 11Be | 5 |
| 1.2 | Détails du produit | 6 |
| 2 | Installer 11Be sur votre casque | 7 |
| 2.1 | Retrait des caches du module de casque gauche/droit | 7 |
| 2.2 | Retrait du cache du module arrière du casque | 7 |
| 2.3 | Retrait des mousses de joues du casque | 7 |
| 2.4 | Installation du module BMS | 8 |
| 2.5 | Installation du module Bluetooth | 9 |
| 2.6 | Installation de microphone sur perche pour casques jet et casques système | 10 |
| 2.7 | Installation d'un microphone Velcro flaire et d'un haut-parleur gauche pour casques intégraux | 11 |
| 2.8 | Installation du haut-parleur droit | 12 |
| 3 | Démarrer avec 11Be | 13 |
| 3.1 | Allumez l'appareil | 13 |
| 3.2 | Éteignez l'appareil | 13 |
| 3.3 | L'annonce de mise hors tension sera jouée et l'appareil sera éteint | 13 |
| 4 | Alimentation - Veille, charge et batterie externe | 14 |
| 4.1 | Le module Bluetooth entre en mode veille | 14 |
| 4.2 | Charger le produit | 14 |
| 4.3 | Fonctionnement de la batterie externe (lors de la charge) | 14 |
| 4.4 | Réinitialisation d'usine Bluetooth | 14 |
| 5 | Modifiez le guidage vocal de votre appareil à l'aide de l'application mobile | 15 |
| 6 | Mettre à jour le firmware à l'aide de l'application mobile | 16 |
| 7 | Guide des étapes de charge de la batterie | 17 |
| 8 | Utilisation de la fonction téléphone et de la fonction de contrôle du volume | 18 |

Table des matières

| | | |
|-----------|---|-----------|
| 9 | Utilisation de la fonction d'écoute de musique | 18 |
| 10 | Commencez à coupler votre téléphone en mode de configuration Bluetooth | 19 |
| 10.1 | Start / end Bluetooth setting mode | 19 |
| 10.2 | Pairing your phone in Bluetooth setting mode | 19 |
| 11 | Démarrer l'appairage intercom en mode de configuration Bluetooth | 20 |
| 11.1 | Démarrer l'appairage intercom en mode de configuration Bluetooth | 20 |
| 12 | Se connecter à un interphone avec un ami | 21 |
| 12.1 | Couplage de l'appareil 1 Connexion interphone | 21 |
| 12.2 | Couplage de l'appareil 2 Connexion interphone | 21 |
| 12.3 | Couplage d'un 3ème appareil Connexion interphone | 21 |
| 13 | SMART HJC Connexion de l'interphone avec d'autres appareils | 22 |
| 13.1 | Exécution du mode de couplage intercom universel SMART HJC (50B / 21B / 11B) | 22 |
| 13.2 | Exécution du mode de couplage intercom SMART HJC (11Be) | 22 |
| 14 | Téléchargez l'application mobile pour smartphone | 23 |
| 14.1 | Téléchargez notre application mobile dédiée | 23 |
| 14.2 | Application mobile OTA (Over-The-Air) | 23 |
| 15 | Premiers pas avec l'application mobile 1 | 24 |
| 16 | Premiers pas avec l'application mobile 2 | 25 |
| 16.1 | Mise sous tension | 25 |
| 16.2 | Mise hors tension | 25 |
| 16.3 | Couplage automatique du téléphone | 25 |
| 16.4 | Paramètres Bluetooth > Couplage du téléphone | 25 |

Table des matières

| | |
|---|----|
| 17 Premiers pas avec l'application mobile 3 | 26 |
| 17.1 Paramètres Bluetooth > Couplage intercom [Connexion d'amis intercom] | 26 |
| 17.2 Démarrer/terminer un appel interphone | 26 |
| 18 Sélection du mode de fonctionnement | 27 |
| 19 Bluetooth principal | 28 |
| 20 Statut d'appariement | 29 |
| 21 Paramètres audio Bluetooth | 30 |
| 22 Mise à jour Bluetooth | 31 |
| 23 Informations d'authentification | 32 |

Dans la boîte

Contenu du package SMART HJC 11Be



SMART HJC 11Be

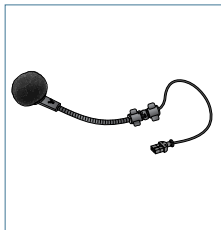

Microphone filaire
pour casques
modulaires/ouverts



Microphone filaire
pour casque intégral

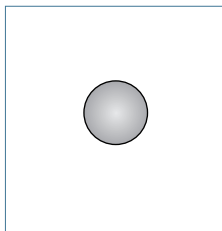

Bande velcro
pour microphone filaire
(fournie ci-jointe)

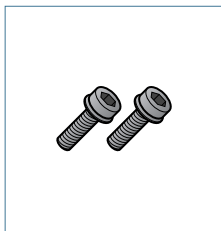

Vis

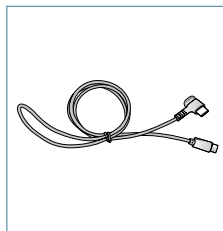

Câble de charge USB
(USB C vers C)

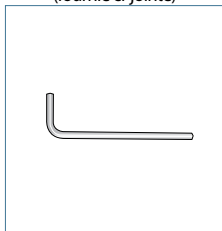

Clé hexagonale

Détails du produit

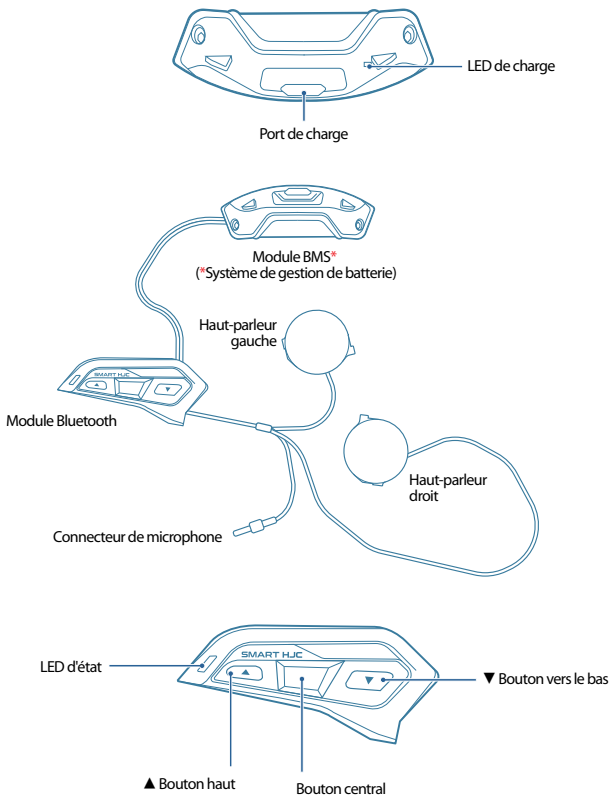

Installer 11Be sur votre casque

Retrait des caches du module de casque gauche/droit

Appuyez sur le levier de fixation du cache gauche/droit et faites-le glisser en biais comme indiqué sur l'image ci-dessous pour le retirer.

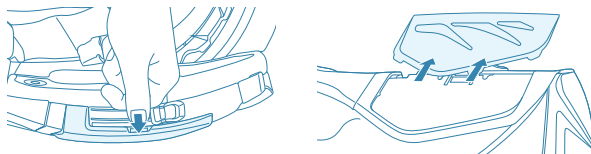

Retrait du cache du module arrière du casque

Utilisez la clé hexagonale fournie pour desserrer les deux vis courtes sur le couvercle arrière du casque et retirez le couvercle.

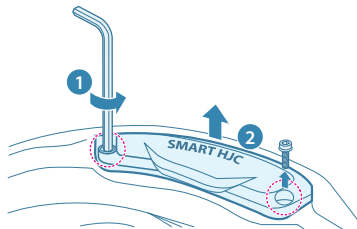

Retrait les mousses de joues du casque

Retirez les mousses de joues du casque en retirant le bouton-pression les mousses de joues fixé au casque.

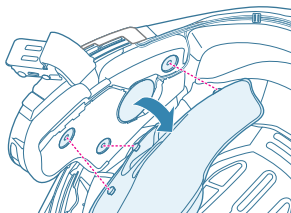

Installation du module BMS

1. Avec le port USB du module BMS face au bas du casque, tirez la protection en caoutchouc vers le haut, puis insérez le module BMS. Insérez-le dans la fente.

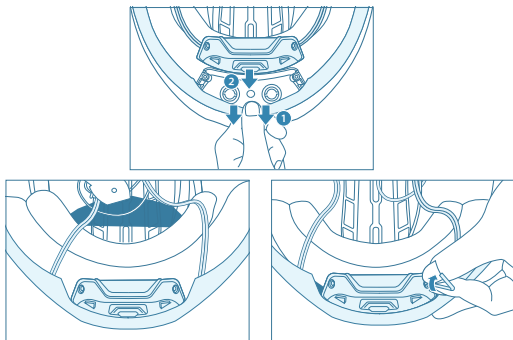

2. Utilisez les boulons de clé et le tournevis fournis pour fixer le module au casque.

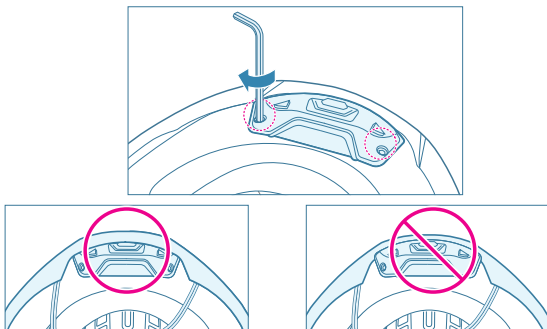

NOTE

La protection en caoutchouc du casque ne doit pas être coincée entre le module BMS et le logement.

Installation du module Bluetooth

1. Vérifiez les pièces de fixation sur les images supérieure et inférieure du module Bluetooth.
2. Placez-le dans la rainure de fixation du module du casque comme indiqué sur l'image et fixez-le en le poussant dans le sens de la flèche jusqu'à ce que vous entendiez un clic.
3. Regardez le bas du casque et vérifiez s'il est correctement installé. (Flèche d'image)

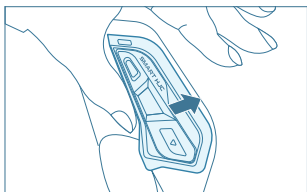
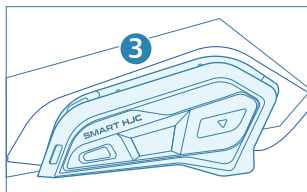
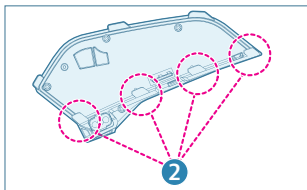
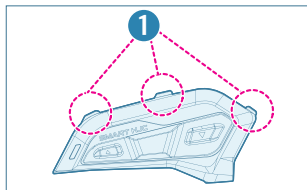

Installation de microphone sur perche jet et casques système

1. Placez la saillie de fixation du microphone sur tige dans la rainure du casque EPS.
2. Insérez d'abord la saillie de fixation longue, puis insérez la saillie de fixation courte pour terminer la fixation.

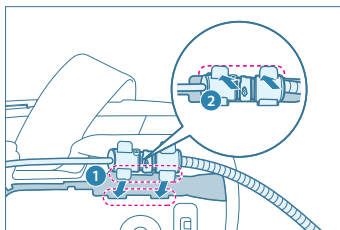

3. Fixez le fil du microphone à la rainure EPS du casque et insérez le fil restant dans la rainure d'installation du haut-parleur.

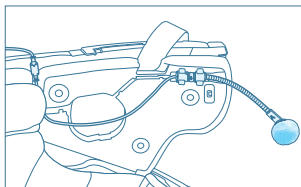
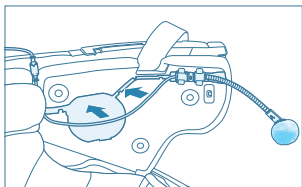

Lors de l'installation du haut-parleur de direction du microphone, placez le fil du microphone restant sous la longue rainure de fixation du haut-parleur, installez la saillie de fixation du haut-parleur dans la rainure de fixation EPS du casque et connectez-la au connecteur du microphone du module Bluetooth.

NOTE

Lors de l'installation, assurez-vous que le fil du microphone n'est pas pressé contre le haut-parleur.

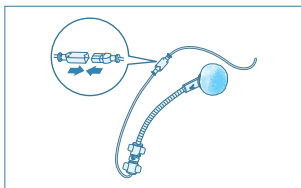
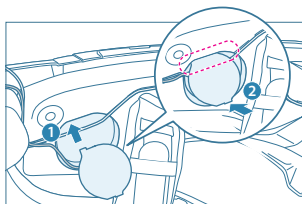

Installation d'un microphone Velcro filaire et d'un haut-parleur gauche pour casques intégrés

1. Retirez la bande adhésive Velcro du microphone fourni et fixez-la à l'intérieur de la mentonnière de la casque. Fixez le microphone filaire à la bande Velcro.

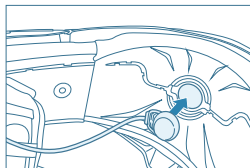
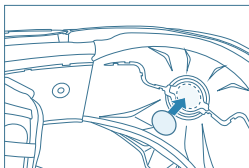
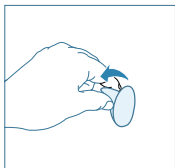

2. Fixez le fil du microphone à la rainure EPS du casque et insérez le fil restant dans la rainure d'installation du haut-parleur.

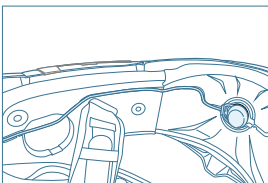
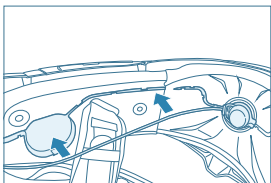

3. Lors de l'installation du haut-parleur gauche, placez le fil du microphone restant sous la longue rainure de fixation du haut-parleur et appuyez sur la saillie de fixation du haut-parleur. Installez-le dans la rainure de fixation EPS du casque et connectez-le au connecteur du microphone du module Bluetooth.

NOTE

Lors de l'installation, assurez-vous que le fil du microphone n'est pas pressé contre le haut-parleur.

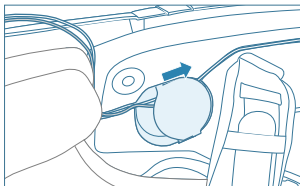
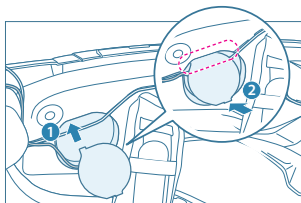

4. Reportez-vous au schéma de connexion du connecteur du microphone dans le chapitre ci-dessus.

Installation du haut-parleur droit

1. Retirez les deux boutons-pression intérieurs du plafond à l'arrière du casque.
2. Faites passer le haut-parleur droit et le fil à travers l'intérieur du matériau intérieur du plafond du casque.
3. Insérez d'abord la longue saillie de fixation du haut-parleur droit dans la rainure de fixation vers le bas du casque, puis insérez la courte saillie de fixation dans la partie supérieure du casque. Veuillez l'insérer dans la rainure de fixation de direction.
4. Fixez un bouton-pression sur le côté droit du matériau intérieur du plafond à l'arrière du casque, organisez le câblage, puis fixez le reste.

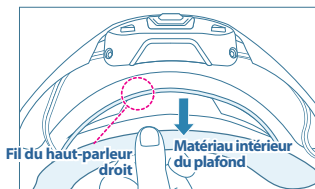
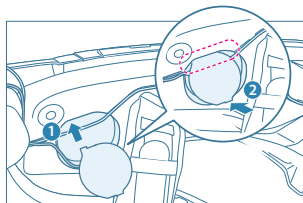
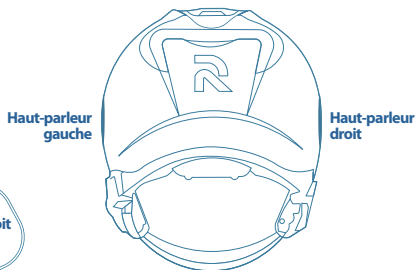
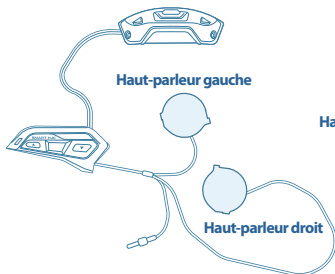

Démarrer avec 11Be

Allumez l'appareil

Appuyez simultanément sur les boutons ▲ Haut et Central de l'appareil pendant 1,5 seconde jusqu'à ce que vous entendiez un bip. L'annonce de mise sous tension retentira et l'appareil démarrera.

Éteignez l'appareil

L'appareil étant allumé, maintenez simultanément enfoncés le bouton ▲ Haut et le bouton Central pendant 1,5 seconde jusqu'à ce que vous entendiez un bip.

L'annonce de mise hors tension sera jouée et l'appareil sera éteint.

Couplage automatique du téléphone

Lorsque vous allumez l'appareil après l'avoir acheté pour la première fois, il entrera automatiquement en mode de couplage du téléphone. Recherchez l'appareil à l'aide de la barre de recherche Bluetooth dans les paramètres du téléphone et connectez-le.

(Appuyez deux fois sur la touche ▼ vers le bas en mode appairage pour quitter ce mode.)

LED Bluetooth

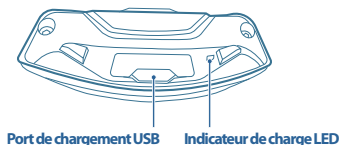
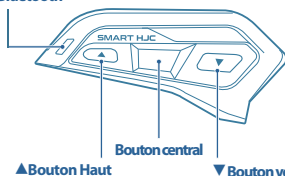



| mode | Actions clés | LED Bluetooth | Guidage vocal | Bip sonore |
|-----------------------|---|-----------------------|------------------------|------------|
| Allumer | ▲ + Centre (appuyer pendant 1,5 seconde) | | Mise en marche | Bip x 1 |
| Éteindre | ▲ + Centre (appuyer pendant 1,5 seconde) | | Extinction | Bip x 1 |
| Couplage téléphonique | | Clignotement cyclique | Appairage du téléphone | - |

Alimentation - Veille, charge et batterie externe

Le module Bluetooth entre en mode veille

1. Après 5 minutes de déconnexion entre le Bluetooth et le smartphone, le module Bluetooth s'éteint automatiquement. À ce moment, même si l'EDR CAM enregistre, le module Bluetooth cesse de fonctionner et s'éteint.
2. Pour utiliser à nouveau le module Bluetooth, allumez-le et reconnectez-le à votre smartphone via Bluetooth.

Charger le produit

1. Charge à partir d'un périphérique de charge USB à entrée 5V et prend en charge le connecteur de type USB-C.
2. La LED s'allume () lorsque le produit est en charge / () lorsqu'il est complètement chargé.
3. Veuillez éteindre le produit pour le charger. (Par mesure de sécurité, la charge de la batterie n'est pas prise en charge lorsque le produit est en fonctionnement.)

Fonctionnement de la batterie externe (lors de la charge)

Lorsqu'une batterie externe est connectée, le fonctionnement du produit est pris en charge et le voyant BMS s'allume (). (Pour des raisons de sécurité, la fonction de surveillance de charge intelligente* est activée lorsque le produit est en fonctionnement.)

*Fonction de surveillance de charge intelligente

Cette fonction maintient le niveau de batterie de l'appareil lorsque la batterie externe est connectée, évitant ainsi toute surcharge et gaspillage d'énergie. Elle fonctionne lorsque la batterie externe est connectée et se désactive automatiquement lorsque la batterie externe est retirée.

Réinitialisation d'usine Bluetooth

Les paramètres d'achat seront réinitialisés.

(Appuyez sur le bouton central pendant 10 secondes.)

Modifiez le guidage vocal de votre appareil à l'aide de l'application mobile

À l'expédition depuis l'usine, le guidage vocal de l'appareil est défini sur l'anglais. Vous pouvez changer la langue de votre appareil souhaité à l'aide de l'application mobile.

NOTE

1. Cette fonction ne peut être exécutée que lorsque le smartphone et l'appareil sont connectés via Bluetooth.
2. Cette fonction ne peut être exécutée que lorsque l'appareil est sous tension ou dispose d'un niveau de batterie de 3 ou plus.
3. N'éteignez pas l'appareil et ne débranchez pas le câble d'alimentation pendant le téléchargement ou la mise à jour. Cela pourrait provoquer un dysfonctionnement.



Dans la fenêtre Modifier la page, appuyez sur le bouton Mettre à jour.

Veillez sélectionner votre langue préférée. Une fois le téléchargement terminé, votre appareil redémarrera.

Langues prises en charge : coréen / anglais / français / allemand / italien / espagnol

Mettre à jour le firmware à l'aide de l'application mobile

Vous pouvez mettre à jour le micrologiciel Bluetooth à l'aide de l'application mobile.

Si le firmware de l'application mobile diffère de celui de l'appareil, un message de mise à jour s'affichera sur l'écran principal Bluetooth de l'application mobile et sur l'écran de mise à jour.

(Cependant, si le firmware de l'appareil est à jour, la demande de mise à jour ne s'affichera pas.)

NOTE

1. Mettez à jour votre application mobile pour conserver le dernier firmware.
2. Cette fonction ne peut être exécutée que lorsque le smartphone et l'appareil sont connectés via Bluetooth.
3. Cette fonction ne peut être exécutée que lorsque l'appareil est sous tension ou dispose d'un niveau de batterie de 3 ou plus.
4. N'éteignez pas l'appareil et ne débranchez pas le câble d'alimentation pendant le téléchargement ou la mise à jour. Cela pourrait provoquer un dysfonctionnement.



État de la mise à jour du micrologiciel

Appuyez sur le bouton Mettre à jour dans la fenêtre Modifier la page.

Appuyez sur le bouton « Mise à jour du micrologiciel ». Une fois le téléchargement et la mise à jour terminés, votre appareil redémarrera automatiquement.

Guide des étapes de charge de la batterie

L'état de charge de la batterie est divisé en 4 niveaux à partir du niveau 0. L'état de charge est affiché sur l'application mobile connectée et si une charge est nécessaire, un son d'avertissement vocal de charge est émis au démarrage de l'appareil.



Guide d'état de charge Bluetooth

| Niveau | État de charge Bluetooth | Guidage vocal |
|---------|--------------------------|--------------------|
| Étape 0 | Avertissement de charge | Batterie faible BT |
| Étape 1 | normale | - |
| Étape 2 | Complètement chargé | - |
| Étape 3 | | |
| Étape 4 | | |

Utilisation de la fonction téléphone et de la fonction de contrôle du volume

| mode | Actions clés | LED Bluetooth | Guidage vocal | Bip sonore |
|------------------------------------|------------------------------|----------------|---------------|------------|
| Le téléphone sonne | - | /// Clignotant | - | - |
| Répondre au téléphone | Centre (appuyer une fois) | /// | - | Bip x 1 |
| Rejeter l'appel | Centre (double pression) | /// | - | Bip x 1 |
| Raccrocher [pendant un appel] - | Centre (double pression) | /// | - | Bip x 1 |
| Augmenter le volume du casque | ▲ (appuyer une fois) | | - | Bip x 1 |
| Baisser le volume du casque | ▼ (appuyer une fois) | | - | Bip x 1 |

Augmenter le volume
(appuyer une fois)

Baisser le volume
(appuyer une fois)

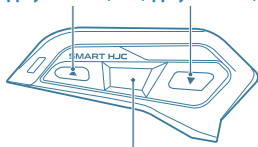

Répondre à un appel (appuyer une fois)
Rejeter l'appel (double appui)
Raccrocher (appuyer deux fois)

Écouter de la musique
(maintenir enfoncé pendant 1 seconde)
Mettre la musique en pause
(maintenir enfoncé pendant 1 seconde)

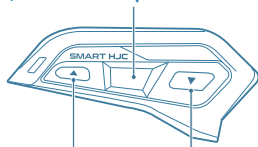

Chanson suivante
(maintenez enfoncé
pendant 1 seconde)

Chanson précédente
(maintenez enfoncé
pendant 1 seconde)

Utilisation de la fonction d'écoute de musique

| mode | Actions clés | LED Bluetooth | Guidage vocal | Bip sonore |
|------------------------|---------------------------------------|---------------|---------------|------------|
| Jouer de la musique | Centre (appuyer pendant 1 seconde) | /// | - | Bip x 1 |
| arrêt de la musique | Centre (appuyer pendant 1 seconde) | /// | - | Bip x 1 |
| Chanson suivante | ▲ (appuyer pendant 1 seconde) | /// | - | Bip x 1 |
| Chanson précédente | ▼ (appuyer pendant 1 seconde) | /// | - | Bip x 1 |

Commencez à coupler votre téléphone en mode de configuration Bluetooth

Le couplage du téléphone et le couplage de l'interphone peuvent être effectués en mode de configuration Bluetooth.

Démarrer/terminer le mode de configuration Bluetooth

▼ Appuyez simultanément sur le bouton bas et le bouton central pendant 1 seconde pour accéder au « mode de réglage Bluetooth ».

1. Appuyez deux fois sur le [bouton central] pendant le mode de configuration Bluetooth pour arrêter le mode.
2. Une fois les paramètres d'appairage terminés, le mode de configuration Bluetooth se terminera automatiquement.
3. Si les paramètres d'appairage ne sont pas terminés en mode de configuration Bluetooth, le mode se terminera automatiquement après 10 secondes.

Couplage de votre téléphone en mode de configuration Bluetooth

En mode de configuration Bluetooth, appuyez une fois sur le bouton ▼ vers le bas pour démarrer un nouveau « couplage du téléphone ». L'appairage du téléphone existant sera réinitialisé et son état sera affiché via un message d'aide et un voyant LED. (Voir le tableau d'état d'appairage ci-dessous.)

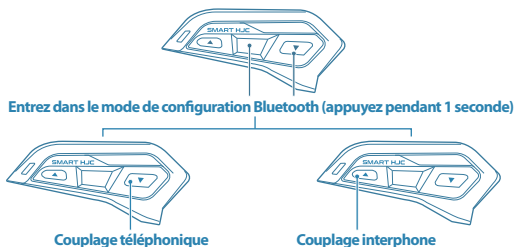

| mode | Actions clés | LED Bluetooth | Guidage vocal | Bip sonore |
|-------------------------------------|--------------------------------------|---------------------------|------------------------|------------|
| Mode de configuration Bluetooth | ▼+Centre (appuyer pendant 1 seconde) | /// | Paramètres BT | Bip x1 |
| Paramètres Bluetooth désactivés | Centre (double pression) | /// | - | Bip x2 |
| Couplage téléphonique | ▼ (appuyer une fois) | /// Clignotement cyclique | Appairage du téléphone | - |
| Couplage interphone* | ▲ (appuyer une fois) | /// Clignotement cyclique | Appairage interphone | - |
| Annuler l'appairage du téléphone | ▼ (double appui) | /// | Appairage annulé | - |
| Annuler l'appairage de l'interphone | ▲ (double appui) | /// | Appairage annulé | - |

Couplage intercom* : Comment connecter et utiliser l'intercom avec un ami couplé se trouve à la page 20.

Démarrer l'appairage intercom en mode de configuration Bluetooth

Démarrer l'appairage intercom en mode de configuration Bluetooth

Lorsque vous et votre ami lancez l'appairage, les appareils s'appairent et se connectent automatiquement. Une fois l'appairage terminé, vous pouvez passer des appels intercom.

1. Entrez les paramètres Bluetooth.
2. Dans les paramètres Bluetooth, appuyez une fois sur le bouton ▲ Haut. L'état s'affiche avec un message d'aide et une LED. (Voir le tableau d'état d'appairage ci-dessus.)
3. L'appareil peut se coupler avec jusqu'à 3 amis et mémorise les informations de couplage même lorsque l'appareil est éteint.
4. Si vous enregistrez un deuxième appariement d'amis alors que le premier ami est enregistré,
 - Le premier appareil d'appairage enregistré devient l'appareil 2 et le deuxième ami enregistré devient l'appareil 1.
 - De même, lorsqu'un troisième ami est enregistré pour l'appairage, le troisième ami enregistré devient l'appareil numéro 1.
 - L'ami qui s'est inscrit en deuxième aura le numéro d'appareil 2, et l'ami qui s'est inscrit en premier aura le numéro d'appareil 3.

NOTE

1. Pour vous connecter à un interphone, vous devez effectuer les actions suivantes avec l'appareil de votre ami à courte distance.
2. Le couplage intercom permet d'enregistrer jusqu'à 3 amis, et la communication intercom n'est possible que 1:1.

Se connecter à un interphone avec un ami

Les informations d'enregistrement des amis enregistrés pour l'appairage intercom sur l'appareil seront enregistrées dans l'appareil, même éteint. Allumez l'appareil et utilisez-le en suivant l'ordre de connexion ci-dessous avec l'ami enregistré.

Couplage de l'appareil 1 Connexion interphone

1. Appuyez une fois sur le **bouton central** de l'appareil à connecter pour passer en mode interphone. Vous entendrez une tonalité.
2. L'appareil récepteur de l'interphone sera averti par une tonalité de réception, et le destinataire terminera la connexion interphone et commencera l'appel en appuyant une fois sur le bouton central.
3. Pendant un appel interphone, appuyez deux fois sur le **[bouton central]** pour mettre fin à l'appel interphone.

Couplage de l'appareil 2 Connexion interphone

Appuyez deux fois sur le **bouton central** de l'appareil à connecter pour accéder au mode interphone. La procédure de connexion est identique à celle de l'appareil 1.

Couplage d'un 3ème appareil Connexion interphone

Appuyez trois fois sur le **bouton central** de l'appareil à connecter pour accéder au mode interphone. La procédure de connexion est identique à celle de l'appareil 1.

Le dernier appareil couplé devient l'appareil 1 et les informations de connexion sont enregistrées dans l'ordre inverse.

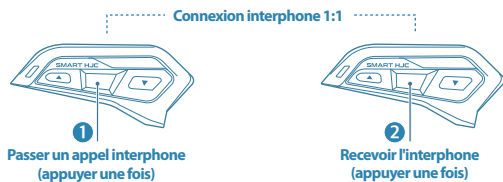

SMART HJC Connexion de l'interphone avec d'autres appareils

Vous pouvez établir une connexion intercom avec le produit (11Be) en réglant le mode d'appairage intercom universel sur le SMART HJC (50B / 21B / 11B). Vous pouvez également établir une connexion intercom avec le SMART HJC (10B / 20B) et le produit SENA via le mode universel.

NOTE

La connexion est possible si le casque Bluetooth SMART HJC prend en charge Bluetooth HFP (Hands-Free Profile).



Département d'interface utilisateur SMART HJC (50B / 21B / 11B)

Exécution du mode de couplage intercom universel SMART HJC (50B / 21B / 11B)

1. Appuyez sur le bouton de tabulation et maintenez-le enfoncé pendant 10 secondes [L'annonce du menu Paramètres sera jouée]
2. Appuyez 3 fois sur le bouton moins [Une annonce de guidage d'appairage intercom universel sera entendue]
3. Appuyez une fois sur le bouton Tab [Entrer en mode de couplage intercom universel]

Exécution du mode de couplage intercom SMART HJC (11Be)

1. Appuyez simultanément sur le bouton central et sur le bouton ▼ bas pour accéder au mode « Paramètres Bluetooth ».
2. En mode « Paramètres Bluetooth », appuyez sur le bouton ▲ Haut pour accéder au mode de couplage intercom.

Lorsque les appareils SMART HJC (50B / 21B / 11B) et (11Be) entrent en mode d'appairage en même temps, une connexion interphone est automatiquement établie et les appels sont possibles.

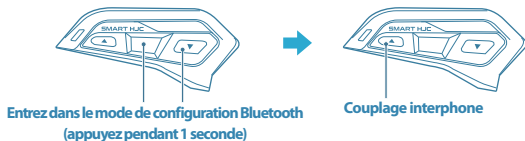

Section de l'interface utilisateur SMART HJC (11Be)

Téléchargez l'application mobile pour smartphone

Téléchargez notre application mobile dédiée

Recherchez « SMART HJC BT (11BC / 11Be) » dans « Google Play Store » pour les téléphones Android ou « App Store » pour les iPhones, ou téléchargez l'application mobile à l'aide du code QR ci-dessous.



Android AOS
Google Play Store



Apple iOS
App Store



Application mobile OTA (Over-The-Air)

1. Vous pouvez télécharger le dernier firmware via la fonction Bluetooth OTA.
2. Vous pouvez télécharger plusieurs langues de guidage vocal via la fonction Bluetooth OTA.

NOTE

Pour une amélioration continue de la qualité, des améliorations des performances de l'appareil et des mises à jour des fonctions peuvent être effectuées sans préNOTE.

Premiers pas avec l'application mobile 1

1. Téléchargez et installez l'application mobile depuis l'App Store.
2. Associez l'appareil dans les paramètres Bluetooth de votre smartphone.
3. Appuyez sur l'icône de l'application installée pour lancer l'application.
4. Lorsque la fenêtre contextuelle d'appairage apparaît pendant l'exécution de l'application, sélectionnez « Appairer » pour vous connecter à l'appareil Bluetooth.

NOTE

1. Si les utilisateurs iOS (Apple) ne parviennent pas à connecter l'application à un appareil Bluetooth, appuyez sur le bouton « Reconnecter » sur l'écran de veille de l'application pour réessayer le couplage.
2. Les utilisateurs d'AOS (Android) seront automatiquement redirigés vers l'écran principal Bluetooth sans fenêtre contextuelle de demande de couplage dans l'application après avoir terminé le couplage de l'appareil dans les paramètres Bluetooth du smartphone.

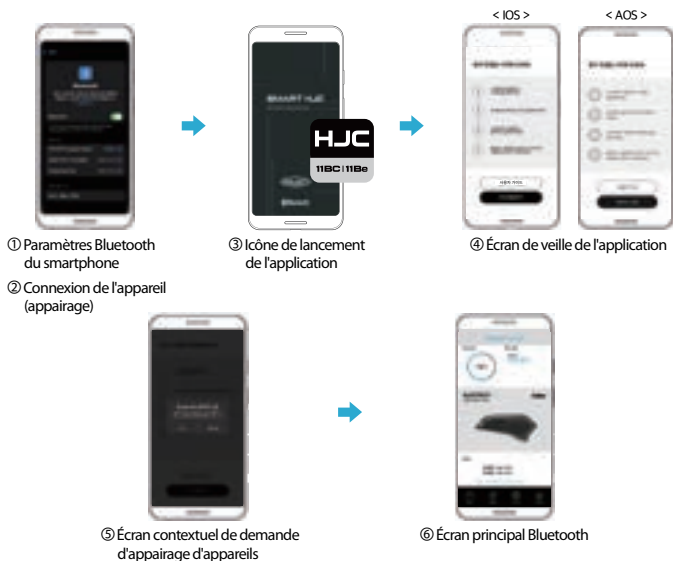

Premiers pas avec l'application mobile 2



Allumer

Appuyez simultanément sur le bouton ▲ (Haut) et le bouton central de l'appareil pendant 1,5 seconde jusqu'à ce que vous entendiez un bip. Vous entendrez le message vocal « Mise sous tension » et l'appareil démarrera.

Éteindre

L'appareil étant allumé, maintenez simultanément les boutons ▲ (Haut) et central enfoncés pendant 1,5 seconde jusqu'à ce que vous entendiez un bip. Vous entendrez alors un message vocal indiquant « Éteindre » et l'appareil s'éteindra.

Couplage automatique du téléphone

Lors de l'achat et de la mise sous tension de l'appareil, celui-ci passe automatiquement en mode appairage. Recherchez l'appareil dans les paramètres Bluetooth de votre smartphone et connectez-le. (Si vous appuyez deux fois sur le bouton ▼ (bas) pendant le mode de couplage du téléphone, le mode sera arrêté.)



Paramètres Bluetooth > Couplage du téléphone

ÉTAPE 1

Après avoir allumé l'appareil, appuyez simultanément sur le bouton central + le bouton ▼ (bas) pendant 1 seconde. L'appareil entrera en mode de configuration Bluetooth avec un bip sonore et le guidage vocal « Paramètres Bluetooth » commencera.

ÉTAPE 2

En mode Bluetooth, appuyez une fois sur le bouton ▼ (bas) pour lancer le jumelage du téléphone. La connexion existante sera automatiquement interrompue et le nouvel appareil jumelé se connectera à votre téléphone.

Annuler l'appairage du téléphone

En mode appairage, appuyez deux fois sur le bouton ▼ (bas) pour passer en mode « Annuler l'appairage ». Sélectionnez ensuite à nouveau l'appareil dans les paramètres Bluetooth de votre smartphone.

Premiers pas avec l'application mobile 3



Paramètre Bluetooth > Couplage intercom [Connexion d'amis intercom]

ÉTAPE 1

Après avoir allumé les deux appareils, maintenez simultanément le bouton central et le bouton ▼ (bas) de chaque appareil enfoncés pendant 1 seconde. Dès que vous entendez un bip et que vous entrez en mode de configuration Bluetooth, appuyez une fois sur le bouton ▲ (haut) de chaque appareil. Vous entendrez le message vocal « Couplage intercom ». Des bips répétés indiqueront le processus de couplage, et l'autre appareil se recherchera automatiquement.

ÉTAPE 2

Après le guidage vocal « Couplage interphone », les deux appareils se connecteront automatiquement à la communication interphone.

Annuler l'appairage de l'interphone

En mode d'appairage intercom, appuyez deux fois sur le bouton ▲ (Haut) pour passer en mode « Annuler l'appairage ».



Démarrer/terminer un appel interphone

Pour rappeler un ami récemment associé, appuyez une fois sur le bouton central.

L'interphone se connectera automatiquement avec un bip sonore provenant des deux appareils. Lors d'un appel interphone, si le destinataire ou l'appelant appuie deux fois sur le bouton central, la connexion interphone prend fin.

NOTE

1. Vous pouvez enregistrer jusqu'à 3 amis pour l'interphone. Comment communiquer avec 3 amis ? Veuillez vous référer à la page 21 du Guide de l'utilisateur.
2. L'enregistrement d'un ami intercom n'est réussi que lorsque les deux appareils sont à proximité l'un de l'autre.

Sélection du mode de fonctionnement



① Sélectionnez le mode Bluetooth

Une fois l'appareil et l'application mobile couplés, vous verrez un bouton pour accéder à l'écran principal Bluetooth.

② Guide de l'utilisateur

Vous pouvez consulter le manuel d'utilisation.

③ Vidéo de démarrage rapide

Vous pouvez voir une vidéo de son montage sur un casque.

Bluetooth principal



① État du niveau de la batterie

② Chargement Bluetooth

③ Nom du modèle

④ Vérifiez le dernier firmware

Si le firmware de votre appareil n'est pas à jour, un message d'avertissement rouge apparaîtra.

⑤ Écran d'accueil

Accédez à l'écran de sélection du mode de fonction.

⑥ Statut d'appairage

Vous pouvez vérifier l'état de couplage Bluetooth et interphone et modifier le nom de l'appareil couplé.

⑦ Paramètres audio Bluetooth

Vous pouvez modifier vos paramètres audio Bluetooth.

⑧ Mise à jour Bluetooth OTA

Vous pouvez mettre à jour le micrologiciel Bluetooth et modifier et mettre à jour la langue de guidage vocal de votre appareil.

Statut d'appariement



① Liste des téléphones connectés à mon appareil

La liste des téléphones actuellement connectés à mon appareil via Bluetooth s'affiche. Lors de la première connexion, le numéro Bluetooth unique du téléphone s'affiche. Appuyez sur ce numéro pour modifier le nom et identifier plus facilement l'appareil.

② Liste des interphones connectés à mon appareil

La liste des appareils intercom actuellement connectés à votre appareil s'affichera. Lors de la première connexion, le numéro Bluetooth unique de l'appareil s'affichera. Appuyez sur ce numéro pour modifier le nom et faciliter l'identification de l'appareil.

Paramètres audio Bluetooth

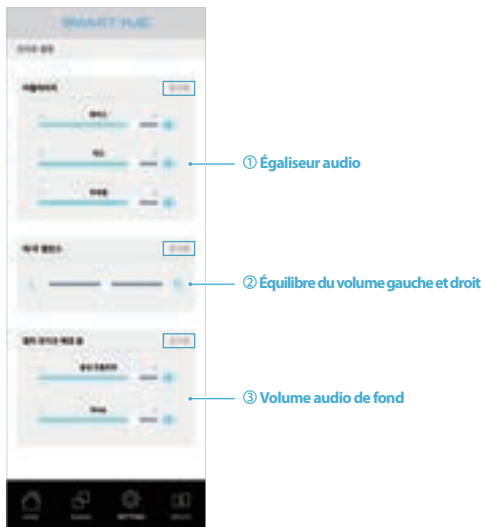

NOTE

1. Après avoir réglé l'audio sur l'appareil, les paramètres seront conservés même si vous éteignez puis rallumez l'appareil.
2. La sélection de Réinitialiser rétablira tous les paramètres de l'appareil à leurs valeurs d'usine.

Mise à jour Bluetooth



① Mise à jour du micrologiciel Bluetooth requise

Lorsque l'application mobile est connectée à votre appareil, elle vérifie automatiquement les mises à jour et vous en informe.

② État du dernier firmware Bluetooth

Si votre appareil utilise le dernier firmware, l'application affichera « Le firmware de votre appareil est la dernière version » et vous pourrez l'utiliser sans mise à jour séparée.

③ Téléchargez et modifiez la langue du guidage vocal de votre appareil.

L'appareil est configuré en usine pour le guidage vocal en anglais. Vous pouvez facilement modifier la langue du guidage vocal de votre appareil en sélectionnant et en téléchargeant votre langue préférée via l'application mobile.

NOTE

1. Maintenez toujours votre application mobile à jour. La dernière version peut gérer et mettre à jour le firmware de votre appareil de manière fiable.
2. La mise à jour ne pourra pas avoir lieu si la batterie de votre appareil n'est pas suffisamment chargée. Veuillez vérifier le niveau de la batterie avant la mise à jour.
3. Si vous avez branché le câble d'alimentation avant la mise à jour, ne le débranchez jamais pendant la mise à jour. Cela pourrait provoquer des erreurs sur l'appareil.
4. Une fois la mise à jour terminée, votre appareil redémarrera automatiquement.

Français

SMART HJC 11BC

KC Certification Information



Certification Number : R-R-M2v-11Be

Product Name : Bluetooth for motorcycle helmets

Model Name : 11Be

Manufacturer/Country of Origin : MtekVision Co., Ltd. / Korea

Distributor : HJC Corporation Cp., Led.

Domestic and international certification information



CE
(EU)



UKC
(UK)



FCC
(USA)



IC
(CAN)



KC
(KOR)

HJC Corporation

HJC Bldg, 1002, Yangjae-daero, Songpa-gu,
Seoul, 05708 Seoul, Republic of Korea
www.hjchelmets.com



HJC Europe

1 Rue BENJAMIN SILLIMAN JR, 67116
REICHSSTETT, FRANCE

Manufacturer

MtekVision Co., Ltd.
Room 333, 42, Changeop-ro, Sujeong-gu,
Seongnam-si, Gyeonggi-do, Republic of Korea
www.mtekvision.com



SMART HJC

11Be

Bluetooth-Kommunikationssystem
für HJC HELME

Benutzerhandbuch
Deutsch/Version 1.0.0



Inhaltsverzeichnis

| | | |
|----------|---|-----------|
| 1 | Produkte im Überblick | 5 |
| 1.1 | SMART HJC 11Be Packungsinhalt | 5 |
| 1.2 | Produktdetails | 6 |
| 2 | Installation von 11Be an Ihrem Helm | 7 |
| 2.1 | Entfernen der linken/rechten Helmmodulabdeckungen | 7 |
| 2.2 | Entfernen der hinteren Helmmodulabdeckung | 7 |
| 2.3 | Abnehmen des Wangenpolsters | 7 |
| 2.4 | Installieren des BMS-Moduls | 8 |
| 2.5 | Installieren des Bluetooth-Moduls | 9 |
| 2.6 | Galgenmikrofoninstallation für Jethelme und Systemhelme | 10 |
| 2.7 | Installation eines kabelgebundenen Klettmikrofons und eines linken Lautsprechers für einen Integralhelm | 11 |
| 2.8 | Einbau des rechten Lautsprechers | 12 |
| 3 | Erste Schritte mit 11Be | 13 |
| 3.1 | Schalten Sie das Gerät ein | 13 |
| 3.2 | Schalten Sie das Gerät aus | 13 |
| 3.3 | Die Power-Off-Ansage wird abgespielt und das Gerät wird ausgeschaltet | 13 |
| 4 | Stromversorgung – Standby & Laden & Externer Akku | 14 |
| 4.1 | Bluetooth-Modul wechselt in den Standby-Modus | 14 |
| 4.2 | Aufladen des Produkts | 14 |
| 4.3 | Externer Akkubetrieb (beim Laden) | 14 |
| 4.4 | Bluetooth-Werksreset | 14 |
| 5 | Ändern Sie die Sprachführung Ihres Geräts mithilfe der mobilen App | 15 |
| 6 | Aktualisieren Sie die Firmware mithilfe der mobilen App | 16 |
| 7 | Schrittanleitung zum Laden des Akkus | 17 |
| 8 | Verwenden der Telefonfunktion und der Lautstärkeregelungsfunktion | 18 |

Inhaltsverzeichnis

| | | |
|-----------|---|-----------|
| 9 | Verwenden der Musikwiedergabefunktion | 18 |
| 10 | Beginnen Sie mit der Kopplung Ihres Telefons im Bluetooth-Einstellungsmodus ... | 19 |
| | 10.1 Bluetooth-Einstellungsmodus starten/beenden | 19 |
| | 10.2 Koppeln Ihres Telefons im Bluetooth-Einstellungsmodus | 19 |
| 11 | Starten Sie die Intercom-Kopplung im Bluetooth-Einstellungsmodus | 20 |
| | 11.1 Starten Sie die Intercom-Kopplung im Bluetooth-Einstellungsmodus | 20 |
| 12 | Mit einem Freund über die Gegensprechanlage verbinden | 21 |
| | 12.1 Koppeln von Gerät 1 Intercom-Verbindung | 21 |
| | 12.2 Koppeln von Gerät 2 Intercom-Verbindung | 21 |
| | 12.3 Koppeln eines dritten Geräts Intercom-Verbindung | 21 |
| 13 | SMART HJC Intercom mit anderen Geräten verbinden | 22 |
| | 13.1 Ausführen des universellen Intercom-Kopplungsmodus von SMART HJC (50B/21B/11B) ... | 22 |
| | 13.2 Ausführen des SMART HJC (11Be) Intercom-Kopplungsmodus | 22 |
| 14 | Laden Sie die Smartphone-App herunter | 23 |
| | 14.1 Laden Sie unsere spezielle mobile App herunter | 23 |
| | 14.2 Mobile App OTA (Over-The-Air) | 23 |
| 15 | Erste Schritte mit der mobilen App 1 | 24 |
| 16 | Erste Schritte mit der mobilen App 2 | 25 |
| | 16.1 Einschalten | 25 |
| | 16.2 Ausschalten | 25 |
| | 16.3 Automatische Telefonkopplung | 25 |
| | 16.4 Bluetooth-Einstellungen > Telefonkopplung | 25 |

Inhaltsverzeichnis

| | | |
|-----------|---|-----------|
| 17 | Erste Schritte mit der mobilen App 3 | 26 |
| | 17.1 Bluetooth-Einstellungen > Intercom-Kopplung [Intercom-Freunde verbinden] | 26 |
| | 17.2 Intercom-Anruf starten/beenden | 26 |
| 18 | Funktionsmodusauswahl | 27 |
| 19 | Bluetooth-Haupt | 28 |
| 20 | Kopplungsstatus | 29 |
| 21 | Bluetooth-Audioeinstellungen | 30 |
| 22 | Bluetooth-Update | 31 |
| 23 | Authentifizierungsinformationen | 32 |

SMART HJC 11Be Packungsinhalt

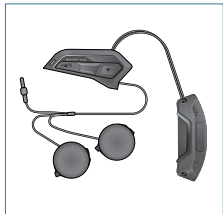

SMART HJC 11Be



Kabelgebundenes
Galgenmikrofon für
modulare/offene Helme

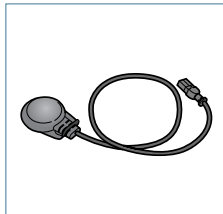

Kabelgebundenes Mikrofon für
Integralhelme

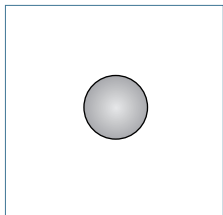

Klettband für
kabelgebundenes Mikrofon
(im Lieferumfang enthalten)

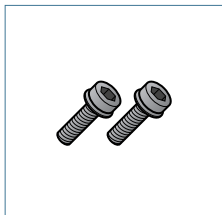

Schrauben

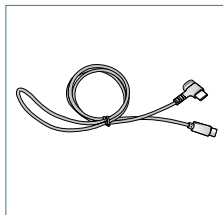

USB-Ladekabel
(USB C auf C)

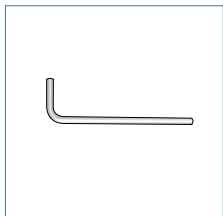

Inbusschlüssel

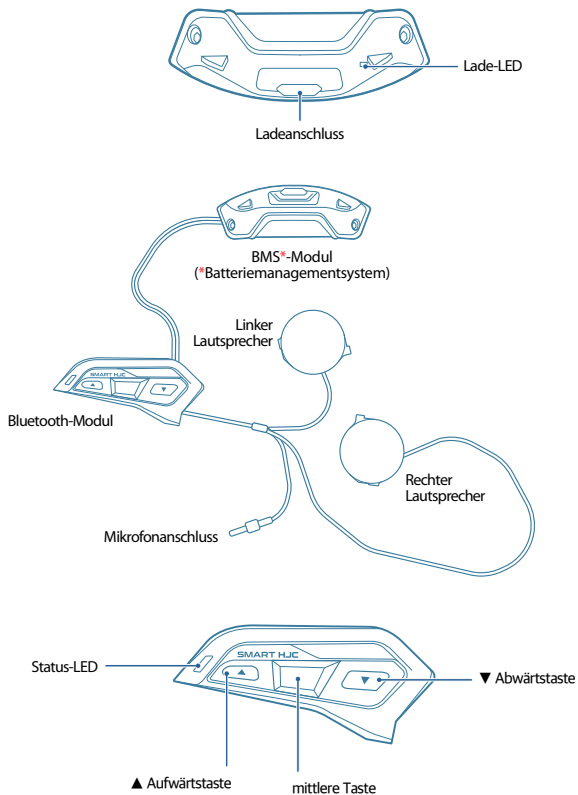

Installation von 11Be an Ihrem Helm

Entfernen der linken/rechten Helmmoduleabdeckungen

Drücken Sie die Befestigungshebel an der linken/rechten Abdeckung und schieben Sie sie schräg, wie in der Abbildung unten gezeigt, um sie zu trennen.

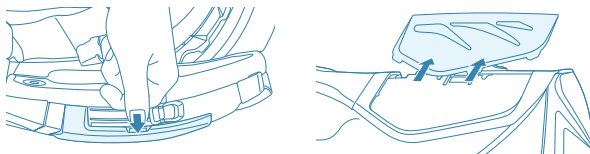

Entfernen der hinteren Helmmoduleabdeckung

Lösen Sie mit dem mitgelieferten Inbusschlüssel die beiden kurzen Schrauben an der hinteren Abdeckung des Helms und entfernen Sie die Abdeckung.

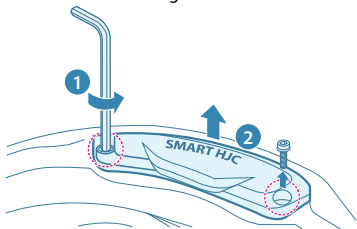

Abnehmen des Wangenpolsters

Entfernen Sie die Wangenpolster vom Helm, indem Sie die an den Wangenpolstern befestigten Druckknöpfe entfernen.

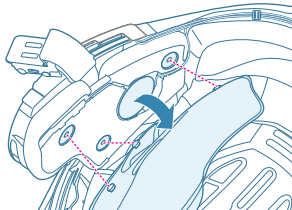

Installieren des BMS-Moduls

1. Platzieren Sie den USB-Anschluss des BMS-Moduls mit Blick auf die Unterseite des Helms, ziehen Sie den Gummischutz nach oben und stecken Sie dann das BMS-Modul ein. Stecken Sie es in den Schlitz.

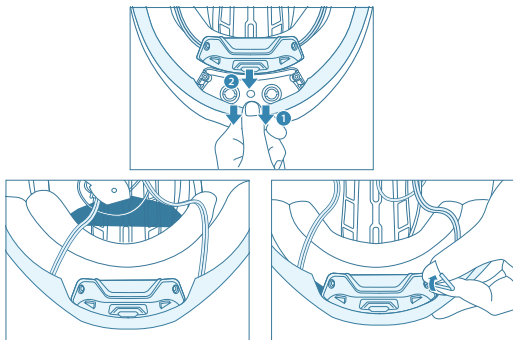

2. Verwenden Sie die mitgelieferten Schraubenschlüssel und den Schraubenschlüsseldreher, um das Modul am Helm zu befestigen.

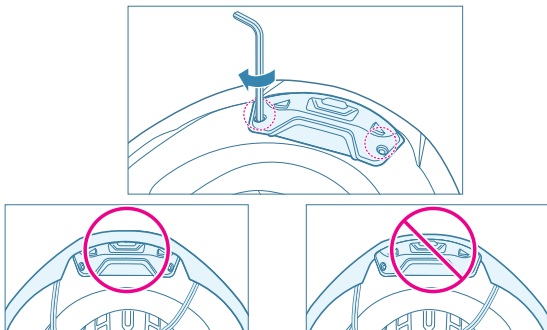

NOTIZ

Stellen Sie sicher, dass der Gummischutz am Helm nicht zwischen BMS-Modul und Steckplatz eingeklemmt ist.

Installieren des Bluetooth-Moduls

1. Überprüfen Sie die Befestigungsteile des oberen Bildes **1** und unteren Bildes **2** des Bluetooth-Moduls.
2. Positionieren Sie es wie in Abbildung **3** gezeigt in der Modulbefestigungsnut des Helms und drücken Sie es in Pfeilrichtung, bis Sie ein Klicken hören.
3. Schauen Sie sich die Unterseite des Helms an und prüfen Sie, ob er richtig sitzt.
(Abbildung **4** Pfeil)

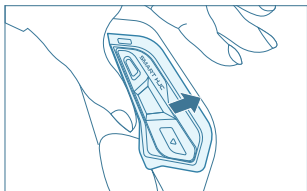
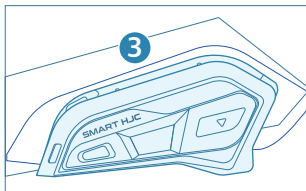
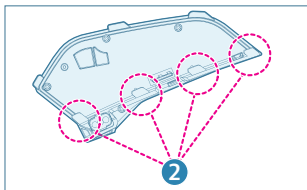
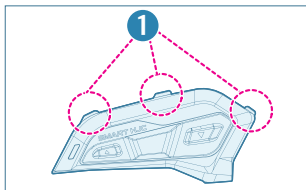

Galgenmikrofoninstallation für Jethelme und Systemhelme

1. Positionieren Sie die Befestigungsöse des Galgenmikrofons in der Nut am Helm-EPS.
2. Führen Sie zuerst den langen Befestigungsvorsprung und dann den kurzen Befestigungsvorsprung ein, um die Fixierung abzuschließen.

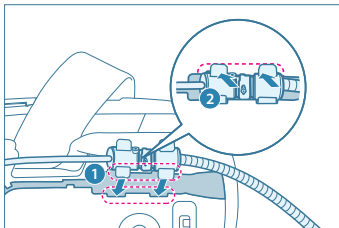

3. Befestigen Sie das Mikrofonkabel in der EPS-Rille des Helms und führen Sie das restliche Kabel in die Nut ein, um die Lautsprechereinheit zu installieren.

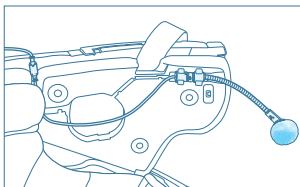
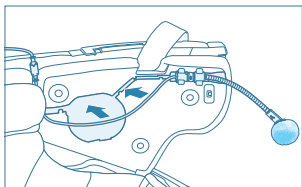

Legen Sie beim Einbau der Mikrofon-Richtungslautsprechereinheit das verbleibende Mikrofonkabel unter die lange Lautsprecherbefestigungsnut, setzen Sie den Lautsprecherbefestigungsvorsprung in die EPS-Befestigungsnut des Helms ein und verbinden Sie ihn dann mit dem Mikrofonanschluss des Bluetooth-Moduls.

NOTIZ

Achten Sie beim Einbau darauf, dass das Mikrofonkabel nicht auf die Lautsprechereinheit drückt.

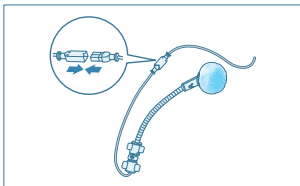
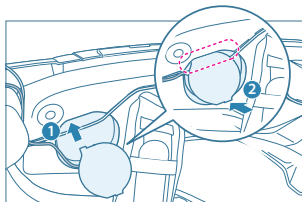

Installation eines kabelgebundenen Klettmikrofons und eines linken Lautsprechers für einen Integralhelm

1. Entfernen Sie die Klebebandabdeckung des mitgelieferten Mikrofon-Klettverschlusses, befestigen Sie ihn an der Innenseite des Kinnschutzes des Helms und befestigen Sie dann das kabelgebundene Mikrofon am Klettverschluss.

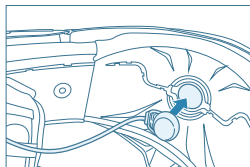
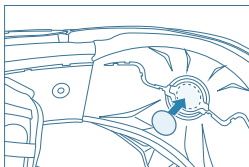
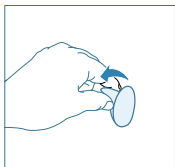

2. Befestigen Sie das Mikrofonkabel in der EPS-Rille des Helms und führen Sie das restliche Kabel in die Nut ein, um die Lautsprechereinheit zu installieren.

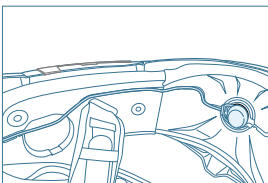
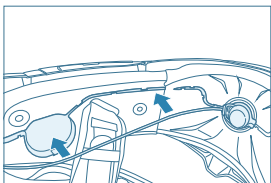

3. Legen Sie beim Einbau der linken Lautsprechereinheit das verbleibende Mikrofonkabel unter die lange Lautsprecherbefestigungsnut, installieren Sie den Lautsprecherbefestigungsvorsprung in die EPS-Befestigungsnut des Helms und verbinden Sie ihn dann mit dem Mikrofonanschluss des Bluetooth-Moduls.

NOTIZ

Achten Sie beim Einbau darauf, dass das Mikrofonkabel nicht auf die Lautsprechereinheit drückt.

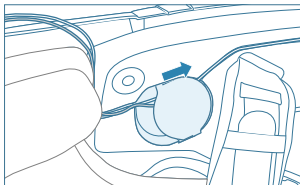
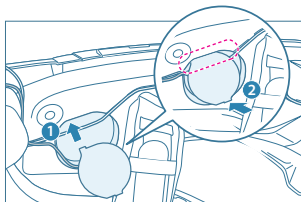

4. NOTIZ Sie das Anschlussdiagramm des Mikrofonanschlusses auf der vorherigen Seite.

Einbau des rechten Lautsprechers

1. Entfernen Sie die beiden Druckknöpfe auf der Rückseite des Helms.
2. Führen Sie den rechten Lautsprecher und das Kabel durch die Innenseite.
3. Führen Sie zuerst den langen Befestigungsvorsprung des rechten Lautsprechers in die Befestigungsnut an der Unterseite des Helms ein und führen Sie dann den kurzen Befestigungsvorsprung in den oberen Teil des Helms ein. Bitte stecken Sie es in die dafür vorgesehene Befestigungsnut.
4. Befestigen Sie einen Druckknopf auf der rechten Seite ordnen Sie dann die Verkabelung und befestigen Sie den verbleibenden.

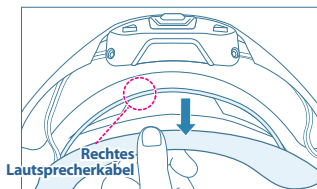
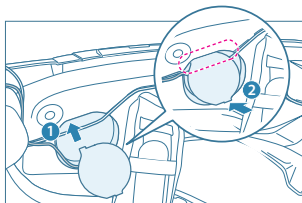
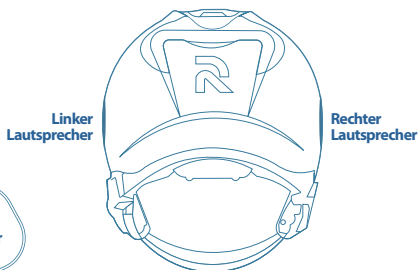
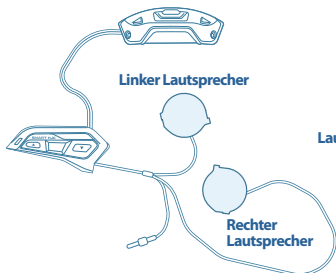

Erste Schritte mit 11Be

Schalten Sie das Gerät ein

Drücken Sie die ▲ Aufwärtstaste und die mittlere Taste am Gerät gleichzeitig 1,5 Sekunden lang, bis ein Piepton ertönt. Die Einschaltmeldung ertönt und das Gerät startet.

Schalten Sie das Gerät aus

Halten Sie bei eingeschaltetem Gerät die Taste ▲ Aufwärts und die mittlere Taste gleichzeitig 1,5 Sekunden lang gedrückt, bis Sie einen Piepton hören.

Die Power-Off-Ansage wird abgespielt und das Gerät wird ausgeschaltet.

Automatische Telefonkopplung

Wenn Sie das Gerät nach dem Kauf zum ersten Mal einschalten, wechselt es automatisch in den Telefonkopplungsmodus. Suchen Sie das Gerät mithilfe der Bluetooth-Suchleiste im Telefoneinstellungsmenü und verbinden Sie es.

(Durch zweimaliges Drücken der Abwärtstaste ▼ im Telefonkopplungsmodus wird der Modus beendet.)

Bluetooth-LED

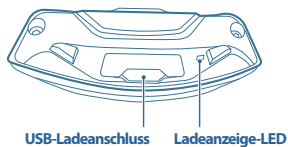
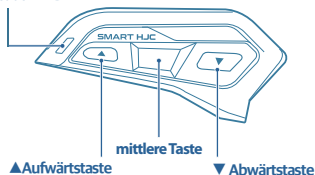



| Modus | Wichtige Maßnahmen | Bluetooth-LED | Sprachführung | Piepton |
|-----------------|-------------------------------------|-----------------|-----------------|-------------|
| Einschalten | ▲ + Mitte (1,5 Sekunden drücken) | /// | Einschalten | 1 x Piepton |
| Ausschalten | ▲ + Mitte (1,5 Sekunden drücken) | /// | Ausschalten | 1 x Piepton |
| Telefonkopplung | | /// Einschalten | Telefon Pairing | - |

Bluetooth-Modul wechselt in den Standby-Modus

1. Nach 5 Minuten Trennung zwischen Bluetooth und Smartphone schaltet sich das Bluetooth-Modul automatisch aus. Auch wenn die EDR CAM aufgezeichnet, stoppt das Bluetooth-Modul den Betrieb und schaltet sich aus.
2. Um das Bluetooth-Modul wieder zu verwenden, schalten Sie es ein und verbinden Sie es erneut über Bluetooth mit Ihrem Smartphone.

Aufladen des Produkts

1. Lädt über ein USB-Ladegerät mit 5-V-Eingang und unterstützt einen Anschluss vom Typ USB-C.
2. Die LED leuchtet (), wenn das Produkt geladen wird / (), wenn es vollständig geladen ist.
3. Schalten Sie das Produkt zum Laden aus.
(Aus Sicherheitsgründen ist das Laden des Akkus während des Betriebs nicht möglich.)

Externer Akkubetrieb (beim Laden)

Wenn eine externe Batterie angeschlossen ist, wird der Produktbetrieb unterstützt und die BMS-LED leuchtet (). (Aus Sicherheitsgründen ist die intelligente Ladeüberwachungsfunktion* aktiv, wenn das Produkt in Betrieb ist.)

* Intelligente Ladeüberwachungsfunktion

Diese Funktion hält den Akkustand des Geräts konstant, wenn der externe Akku angeschlossen ist, und verhindert so Überladung und Stromverschwendung. Sie funktioniert, solange der externe Akku angeschlossen ist, und wird automatisch deaktiviert, sobald der externe Akku entfernt wird.

Bluetooth-Werksreset

Es wird auf die Einstellungen beim Kauf des Produkts initialisiert.
(Drücken Sie die mittlere Taste 10 Sekunden lang.)

Ändern Sie die Sprachführung Ihres Geräts mithilfe der mobilen App

Bei Auslieferung ab Werk ist die Sprachführung des Geräts auf Englisch eingestellt. Sie können die Sprache Ihres gewünschten Geräts über die mobile App ändern.

NOTIZ

1. Diese Funktion kann nur ausgeführt werden, wenn Smartphone und Gerät über Bluetooth verbunden sind.
2. Diese Funktion kann nur ausgeführt werden, wenn das Gerät eingeschaltet ist oder der Akkustand 3 oder höher beträgt.
3. Schalten Sie das Gerät während des Download- und Aktualisierungsvorgangs nicht aus und ziehen Sie nicht das Netzkabel ab. Dies kann zu Fehlfunktionen führen.



Tippen Sie im Fenster "Seite ändern" auf die Schaltfläche "Aktualisieren".

Bitte wählen Sie Ihre bevorzugte Sprache. Nachdem der Download auf Ihr Gerät abgeschlossen ist, wird Ihr Gerät neu gestartet.

Unterstützte Sprachen : Koreanisch / Englisch / Französisch / Deutsch / Italienisch / Spanisch

Aktualisieren Sie die Firmware mithilfe der mobilen App

Sie können die Bluetooth-Firmware mit der mobilen App aktualisieren. Wenn die in der mobilen App enthaltene Firmware und die Firmware-Version des Geräts unterschiedlich sind, wird auf dem Bluetooth-Hauptbildschirm und dem Aktualisierungsbildschirm der mobilen App eine Meldung zur Firmware-Aktualisierung angezeigt.

(Wenn die Firmware des Geräts jedoch die neueste Version ist, wird die Aktualisierungsanforderung nicht angezeigt.)

NOTIZ

1. Aktualisieren Sie Ihre mobile App, um die neueste Firmware zu erhalten.
2. Diese Funktion kann nur ausgeführt werden, wenn Smartphone und Gerät über Bluetooth verbunden sind.
3. Diese Funktion kann nur ausgeführt werden, wenn das Gerät eingeschaltet ist oder der Akkustand 3 oder höher beträgt.
4. Schalten Sie das Gerät während des Download- und Aktualisierungsvorgangs nicht aus und ziehen Sie nicht das Netzkabel ab. Dies kann zu Fehlfunktionen führen.

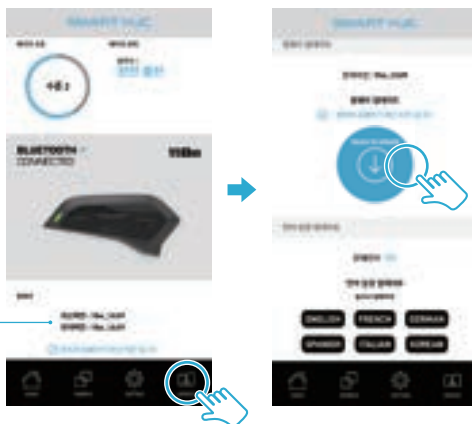

Tippen Sie im Fenster "Seite ändern" auf die Schaltfläche "Aktualisieren".

Tippen Sie auf die Schaltfläche "Firmware-Update". Sobald Download und Update abgeschlossen sind, wird Ihr Gerät automatisch neu gestartet.

Schrittanleitung zum Laden des Akkus

Der Ladezustand des Akkus ist in 4 Stufen ab Stufe 0 unterteilt. Der Ladezustand wird in der verbundenen mobilen App angezeigt und wenn ein Aufladen erforderlich ist, ertönt beim Starten des Geräts ein Ladewarnton mit Sprachführung.



Bluetooth-Ladestatus-Leitfaden

| Ebene | Bluetooth-Ladestatus | Bluetooth-Ladestatus |
|-----------|------------------------|----------------------------|
| Schritt 0 | Ladewarnung | BT Niedriger Batteriestand |
| Schritt 1 | Normal | - |
| Schritt 2 | Vollständig aufgeladen | - |
| Schritt 3 | | |
| Schritt 4 | | |

Verwenden der Telefonfunktion und der Lautstärkeregelungsfunktion

| Modus | Wichtige Maßnahmen | Bluetooth-LED | Sprachführung | Piepton |
|-------------------------------|----------------------------|---------------|---------------|-------------|
| Das Telefon klingelt | - | /// Blinkend | - | - |
| Beantworten Sie das Telefon | Mitte (einmal drücken) | /// | - | 1 x Piepton |
| Anruf ablehnen | Mitte (zweimal drücken) | /// | - | 1 x Piepton |
| Headset-Lautstärke erhöhen | Mitte (zweimal drücken) | /// | - | 1 x Piepton |
| Headset-Lautstärke erhöhen | ▲ (einmal drücken) | | - | 1 x Piepton |
| Headset-Lautstärke verringern | ▼ (einmal drücken) | | - | 1 x Piepton |

Lautstärke erhöhen
(einmal drücken)

Lautstärke verringern
(einmal drücken)

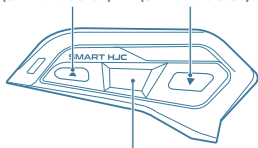

Einen Anruf annehmen (einmal drücken)
Anruf ablehnen (zweimal drücken)
Auflegen (zweimal drücken)

Musik abspielen (1 Sekunde gedrückt halten)
Musik pausieren (1 Sekunde gedrückt halten)

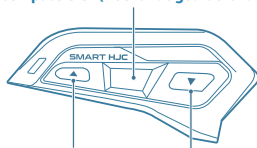

Nächstes Lied
(1 Sekunde gedrückt halten)

Vorheriger Song
(1 Sekunde gedrückt halten)

Verwenden der Musikwiedergabefunktion

| Modus | Wichtige Maßnahmen | Wichtige Maßnahmen | Sprachführung | Piepton |
|-----------------|-----------------------------------|--------------------|---------------|-------------|
| Musik abspielen | Mitte (1 Sekunde lang drücken) | /// | - | 1 x Piepton |
| Musikstopp | Mitte (1 Sekunde lang drücken) | /// | - | 1 x Piepton |
| Nächstes Lied | ▲ (1 Sekunde lang drücken) | /// | - | 1 x Piepton |
| Vorheriges Lied | ▼ (1 Sekunde lang drücken) | /// | - | 1 x Piepton |

Beginnen Sie mit der Kopplung Ihres Telefons im Bluetooth-Einstellungsmodus

Die Kopplung von Telefon und Gegensprechanlage kann im Bluetooth-Einstellungsmodus durchgeführt werden.

Bluetooth-Einstellungsmodus starten/beenden

▼ Drücken Sie die Abwärtstaste und die mittlere Taste gleichzeitig 1 Sekunde lang, um in den "Bluetooth-Einstellungsmodus" zu gelangen.

1. Durch zweimaliges Drücken der [mittleren Taste] im Bluetooth-Einstellungsmodus wird der Modus beendet.
2. Sobald die Kopplungseinstellungen abgeschlossen sind, wird der Bluetooth-Einstellungsmodus automatisch beendet.
3. Wenn die Kopplungseinstellungen im Bluetooth-Einstellungsmodus nicht abgeschlossen werden, wird der Modus nach 10 Sekunden automatisch beendet.

Koppln Ihres Telefons im Bluetooth-Einstellungsmodus

Im Bluetooth-Einstellungsmodus wird durch einmaliges Drücken der Abwärtstaste ▼ eine neue "Telefonkopplung" gestartet. Die bestehende Telefonkopplung wird zurückgesetzt und der Status durch eine Ansage und eine LED angezeigt. (Siehe Kopplungsstatusabelle unten)

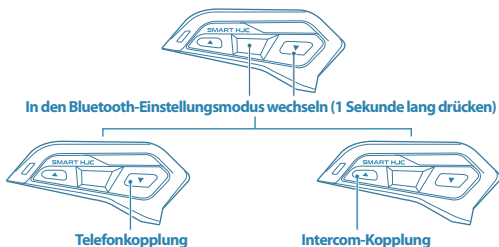

| Modus | Wichtige Maßnahmen | Bluetooth-LED | Sprachführung | Piepton |
|------------------------------|-------------------------------------|-----------------------|---------------------|-------------|
| Bluetooth-Einstellungsmodus | ▼+Mitte (1 Sekunde lang drücken) | /// | BT-Einstellungen | 1 x Piepton |
| Bluetooth-Einstellungen raus | Mitte (zweimal drücken) | // | - | 2 x Piepton |
| Telefonkopplung | ▼ (zweimal drücken) | // Zyklisches Blinken | Telefon-Pairing | - |
| Intercom-Kopplung* | ▲ (zweimal drücken) | // Zyklisches Blinken | Intercom-Pairing | - |
| Telefonkopplung abbrechen | ▼ (zweimal drücken) | // | Pairing abgebrochen | - |
| Intercom-Kopplung abbrechen | ▲ (zweimal drücken) | // | Pairing abgebrochen | - |

Intercom-Kopplung*: Informationen zum Verbinden und Verwenden der Gegensprechanlage mit einem gekoppelten Freund finden Sie auf Seite 20.

Starten Sie die Intercom-Kopplung im Bluetooth-Einstellungsmodus

Wenn Sie und das Gerät Ihres Freundes gemeinsam die Kopplung starten, werden die Geräte automatisch gekoppelt und verbunden. Nach der Kopplung können Sie über die Gegensprechanlage telefonieren.

1. Rufen Sie die Bluetooth-Einstellungen auf.
2. Drücken Sie in den Bluetooth-Einstellungen einmal die Taste ▲ nach oben. Der Status wird mit einer Hinweismeldung und einer LED angezeigt. (Siehe die obige Tabelle zum Pairing-Status.)
3. Das Gerät kann mit bis zu 3 Freunden gekoppelt werden und merkt sich die Kopplungsinformationen, auch wenn das Gerät ausgeschaltet ist.
4. Wenn Sie eine zweite Freundespaarung registrieren, während der erste Freund registriert ist,
 - Das erste registrierte Pairing-Gerät wird zu Gerät 2 und der zweite registrierte Freund wird zu Gerät 1.
 - Wenn ein dritter Freund zur Kopplung registriert wird, wird der dritte registrierte Freund ebenfalls zum Gerät Nummer 1.
 - Der Freund, der sich als Zweiter registriert hat, erhält die Gerätenummer 2 und der Freund, der sich zuerst registriert hat, erhält die Gerätenummer 3.

NOTIZ

1. Um eine Verbindung zu einer Gegensprechanlage herzustellen, müssen Sie die folgenden Aktionen mit dem Gerät Ihres Freundes aus nächster Nähe ausführen.
2. Durch die Intercom-Kopplung können bis zu 3 Freunde registriert werden, eine Intercom-Kommunikation ist jedoch nur 1:1 möglich.

Mit einem Freund über die Gegensprechanlage verbinden

Die Registrierungsdaten von Freunden, die für die Gegensprechanlage registriert sind, bleiben auch bei ausgeschaltetem Gerät gespeichert. Schalten Sie das Gerät ein und verwenden Sie es, indem Sie mit dem registrierten Freund die unten stehende Verbindungsreihenfolge befolgen.

Koppeln von Gerät 1 Intercom-Verbindung

1. Drücken Sie einmal die [mittlere Taste] auf dem zu verbindenden Gerät, um in den Intercom-Verbindungsmodus zu wechseln. Sie hören einen Wählton vom Gerät.
2. Das Gegensprechanlagen-Empfangsgerät wird durch einen Empfangston benachrichtigt und der Empfänger stellt die Gegensprechanlage-Verbindung her und beginnt den Anruf, indem er einmal die mittlere Taste drückt.
3. Drücken Sie während eines Intercom-Anrufs zweimal die [mittlere Taste], um den Intercom-Anruf zu beenden.

Koppeln von Gerät 2 Intercom-Verbindung

Tippen Sie zweimal auf die [mittlere Taste] des zu verbindenden Geräts, um in den Intercom-Verbindungsmodus zu wechseln. Der Vorgang zum Verbinden von Geräten ist derselbe wie beim Verbinden mit der Intercom auf Gerät 1.

Koppeln eines dritten Geräts Intercom-Verbindung

Drücken Sie dreimal die [mittlere Taste] auf dem zu verbindenden Gerät, um in den Intercom-Verbindungsmodus zu wechseln. Der Vorgang zum Verbinden von Geräten ist derselbe wie beim Verbinden mit der Gegensprechanlage auf Gerät 1.

Das zuletzt gekoppelte Gerät wird zu Gerät 1 und die Verbindungsinformationen werden in umgekehrter Reihenfolge gespeichert.

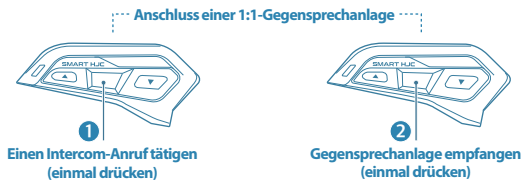

SMART HJC Intercom mit anderen Geräten verbinden

Sie können eine Sprechverbindung mit einem (11Be)-Produkt herstellen, indem Sie die Einstellung des SMART HJC (50B / 21B / 11B)-Produkts auf den universellen Sprechverbindungsmodus umstellen. Über den universellen Modus können Sie auch eine Sprechverbindung mit SMART HJC (10B / 20B) und SENA-Produkten herstellen.

NOTIZ

Eine Verbindung ist möglich, wenn das SMART HJC Bluetooth-Headset Bluetooth HFP (Hands-Free Profile) unterstützt.

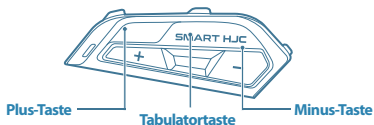

SMART HJC (50B / 21B / 11B) UI-Abteilung

Ausführen des universellen Intercom-Kopplungsmodus von SMART HJC (50B/21B/11B)

1. Halten Sie die Tabulatortaste 10 Sekunden lang gedrückt [Eine Ansage aus dem Einstellungsmenü wird abgespielt]
2. Drücken Sie die Minustaste dreimal [Sie hören eine Ansage zur Kopplung der universellen Gegensprechanlage].
3. Drücken Sie einmal die Tabulatortaste [Universal-Intercom-Kopplungsmodus aktivieren]

Ausführen des SMART HJC (11Be) Intercom-Kopplungsmodus

1. Drücken Sie gleichzeitig die mittlere Taste und die Abwärtstaste ▼, um in den Modus „Bluetooth-Einstellungen“ zu gelangen.
2. Drücken Sie im Modus „Bluetooth-Einstellungen“ die Taste ▲ Nach oben, um in den Intercom-Kopplungsmodus zu wechseln.

Wenn SMARTHJC-Geräte (50B / 21B / 11B) und (11Be) gleichzeitig in den Kopplungsmodus wechseln, wird automatisch eine Intercom-Verbindung hergestellt und Anrufe sind möglich.



SMART HJC (11Be) UI-Abschnitt

Laden Sie die Smartphone-App herunter

Laden Sie unsere spezielle mobile App herunter

Suchen Sie im "Google Play Store" für Android-Telefone oder im "App Store" für iPhones nach "SMART HJC BT (11BC / 11Be)" oder laden Sie die mobile App mit dem unten stehenden QR-Code herunter.



Android AOS
Google Play Store



Apple IOS
App Store



Mobile App OTA (Over-The-Air)

1. Sie können die neueste Firmware über die Bluetooth OTA-Funktion herunterladen.
2. Sie können mehrere Sprachführungssprachen über die Bluetooth-OTA-Funktion herunterladen.

NOTIZ

Zur kontinuierlichen Qualitätsverbesserung können Leistungsverbesserungen des Geräts und Funktionsaktualisierungen ohne vorherige Ankündigung vorgenommen werden.

Erste Schritte mit der mobilen App 1

1. Laden Sie die mobile App aus dem App Store herunter und installieren Sie sie.
2. Koppeln Sie das Gerät in den Bluetooth-Einstellungen Ihres Smartphones.
3. Tippen Sie auf das Symbol der installierten App, um die App zu starten.
4. Wenn beim Ausführen der App das Kopplungs-Popup angezeigt wird, wählen Sie "Koppeln", um eine Verbindung mit dem Bluetooth-Gerät herzustellen.

NOTIZ

1. Wenn es iOS-Benutzern (Apple) nicht gelingt, die App mit einem Bluetooth-Gerät zu verbinden, drücken Sie auf dem Standby-Bildschirm der App die Schaltfläche „Erneut verbinden“, um die Kopplung erneut zu versuchen.
2. AOS-Benutzer (Android) werden nach Abschluss der Gerätekopplung in den Bluetooth-Einstellungen des Smartphones automatisch zum Bluetooth-Hauptbildschirm weitergeleitet, ohne dass innerhalb der App ein Popup mit einer Kopplungsanfrage angezeigt wird.



Erste Schritte mit der mobilen App 2



Einschalten

Halten Sie die Taste ▲ (Aufwärts) und die mittlere Taste am Gerät gleichzeitig 1,5 Sekunden lang gedrückt, bis ein Piepton ertönt. Sie hören die Sprachansage "Einschalten" und das Gerät startet.

Ausschalten

Halten Sie bei eingeschaltetem Gerät die Taste ▲ (Aufwärts) und die mittlere Taste gleichzeitig 1,5 Sekunden lang gedrückt, bis ein Piepton ertönt. Sie hören die Sprachansage "Ausschalten" und das Gerät wird heruntergefahren.

Automatische Telefonkopplung

Wenn Sie das Gerät kaufen und einschalten, wechselt es automatisch in den Telefonkopplungsmodus. Suchen Sie in den Bluetooth-Einstellungen Ihres Smartphones nach dem Gerät und verbinden Sie es. (Wenn Sie im Telefonkopplungsmodus zweimal die Taste ▼ (nach unten) drücken, wird der Modus beendet.)



Bluetooth-Einstellungen > Telefonkopplung

SCHRITT 1

Drücken Sie nach dem Einschalten die mittlere Taste + die Taste ▼ (nach unten) gleichzeitig 1 Sekunde lang. Das Gerät wechselt mit einem Piepton in den Bluetooth-Einstellungsmodus und die Sprachführung "Bluetooth-Einstellungen" beginnt.

SCHRITT 2

Im Bluetooth-Einstellungsmodus wird durch einmaliges Drücken der Taste ▼ (nach unten) die "Telefonkopplung" gestartet. Die bestehende Verbindung wird automatisch getrennt und das neu gekoppelte Gerät verbindet sich mit Ihrem Telefon.

Telefonkopplung abbrechen

Im Telefonkopplungsmodus wechseln Sie durch zweimaliges Tippen auf die Taste ▼ (nach unten) in den Modus "Kopplung abbrechen". Wählen Sie anschließend das Gerät in den Bluetooth-Einstellungen Ihres Smartphones erneut aus.

Erste Schritte mit der mobilen App 3



Bluetooth-Einstellungen > Intercom-Kopplung [Intercom-Freunde verbinden]

SCHRITT 1

Nachdem Sie beide Geräte eingeschaltet haben, halten Sie gleichzeitig die mittlere Taste und die Taste ▼ (nach unten) an jedem Gerät eine Sekunde lang gedrückt. Sobald Sie einen Piepton hören und in den Bluetooth-Einrichtungsmodus wechseln, drücken Sie die Taste ▲ (nach oben) an jedem Gerät einmal. Sie hören die Sprachansage "Intercom-Kopplung". Wiederholte Pieptöne zeigen den Kopplungsvorgang an, und das andere Gerät sucht automatisch nach dem anderen Gerät.

SCHRITT 2

Nach der Sprachführung „Intercom Pairing“ stellen die beiden Geräte automatisch eine Verbindung zur Intercom-Kommunikation her.

Intercom-Kopplung abbrechen

Im Intercom-Kopplungsmodus wechseln Sie durch zweimaliges Drücken der Taste ▲ (Auf) in den Modus "Kopplung abbrechen".



Intercom-Anruf starten/beenden

Um einen kürzlich gekoppelten Freund zurückzurufen, drücken Sie einmal die mittlere Taste. Die Gegensprechanlage stellt automatisch eine Verbindung her, und beide Geräte geben einen Piepton aus. Wenn während eines Intercom-Anrufs entweder der Empfänger oder der Anrufer die mittlere Taste zweimal drückt, wird die Intercom-Verbindung beendet.

NOTIZ

1. Sie können bis zu 3 Freunde für die Gegensprechanlage registrieren. So nutzen Sie die Gegensprechanlage mit 3 Freunden Weitere Informationen finden Sie auf PAGE 21 des Benutzerhandbuchs.
2. Die Anmeldung bei einem Intercom-Freund ist nur erfolgreich, wenn sich die beiden Geräte in unmittelbarer Nähe zueinander befinden.

Funktionsmodusauswahl



① Bluetooth-Modus auswählen

Sobald das Gerät und die mobile App gekoppelt sind, wird eine Schaltfläche zum Aufrufen des Bluetooth-Hauptbildschirms angezeigt.

② Benutzerhandbuch

Sie können das Benutzerhandbuch einsehen.

③ Schnellstartvideo

Sie können sich ein Video ansehen, in dem die Montage an einem Helm gezeigt wird.

Bluetooth-Haupt



① Batterieladezustand

② Bluetooth-Laden

③ Modellname

④ Überprüfen Sie die neueste Firmware

Wenn die Firmware Ihres Geräts nicht auf dem neuesten Stand ist, wird eine rote Warnmeldung angezeigt.

⑤ Startbildschirm

Gehen Sie zum Bildschirm "Funktionsmodusauswahl".

⑥ Kopplungsstatus

Sie können den Bluetooth- und Intercom-Kopplungsstatus überprüfen und den Namen des gekoppelten Geräts bearbeiten.

⑦ Bluetooth-Audioeinstellungen

Sie können Ihre Bluetooth-Audioeinstellungen ändern.

⑧ Bluetooth OTA-Update

Sie können die Bluetooth-Firmware aktualisieren und die Sprache der Sprachführung Ihres Geräts ändern und aktualisieren.

Kopplungsstatus

① Liste der mit meinem Gerät verbundenen Mobiltelefone

② Liste der mit meinem Gerät verbundenen Gegensprechanlagen

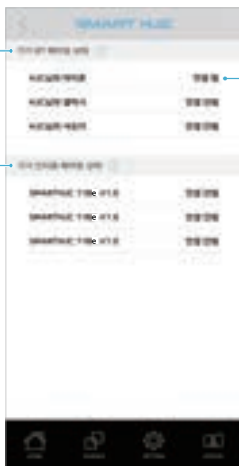

Kopplungsstatus

① Liste der mit meinem Gerät verbundenen Telefone

Es wird eine Liste der aktuell per Bluetooth mit meinem Gerät verbundenen Telefone angezeigt. Beim ersten Verbindungsaufbau wird die eindeutige Bluetooth-Nummer des Telefons angezeigt. Tippen Sie auf diese Nummer, um den Namen zu ändern und das Gerät so leichter zu identifizieren.

② Liste der mit meinem Gerät verbundenen Gegensprechanlagen

Es wird eine Liste der aktuell mit Ihrem Gerät verbundenen Intercom-Geräte angezeigt. Beim ersten Verbindungsaufbau wird die eindeutige Bluetooth-Nummer des Geräts angezeigt. Tippen Sie auf diese Nummer, um den Namen zu ändern und das Gerät so leichter zu identifizieren.

Bluetooth-Audioeinstellungen

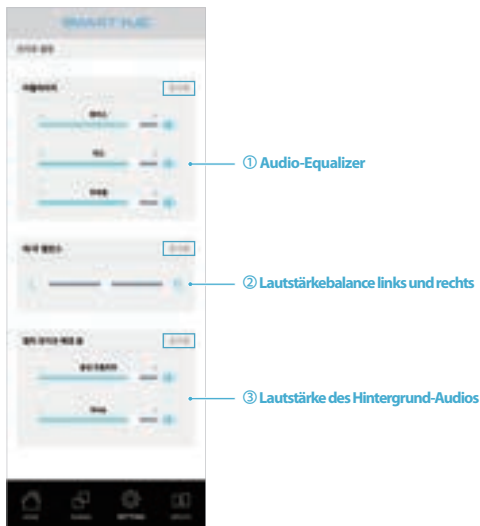

NOTIZ

1. Nachdem Sie den Ton am Gerät angepasst haben, bleiben die Einstellungen erhalten, auch wenn Sie das Gerät aus- und wieder einschalten.
2. Wenn Sie "Zurücksetzen" auswählen, werden alle Einstellungen des Geräts auf die Werkseinstellungen zurückgesetzt.



1 Bluetooth-Firmware-Update erforderlich

Wenn die mobile App mit Ihrem Gerät verbunden ist, sucht sie automatisch nach Updates und benachrichtigt Sie.

2 Bluetooth aktuellster Firmware-Status

Wenn Ihr Gerät die neueste Firmware verwendet, zeigt die App "Die Firmware Ihres Geräts ist die neueste Version" an und Sie können es ohne separates Update verwenden.

3 Laden Sie die Sprachführungssprache Ihres Geräts herunter und ändern Sie sie.

Das Gerät ist werkseitig auf englische Sprachführung eingestellt. Sie können die Sprache der Sprachführung Ihres Geräts ganz einfach ändern, indem Sie Ihre bevorzugte Sprache über die mobile App auswählen und herunterladen.

NOTIZ

1. Halten Sie Ihre mobile App immer auf dem neuesten Stand. Die neueste App kann die Firmware Ihres Geräts zuverlässig verwalten und aktualisieren.
2. Das Update wird nicht fortgesetzt, wenn der Akku Ihres Geräts nicht ausreichend geladen ist. Bitte überprüfen Sie den Akkuladestand vor dem Update.
3. Wenn Sie das Netzkabel vor dem Update angeschlossen haben, trennen Sie es während des Updates auf keinen Fall. Dies kann zu Gerätefehlern führen.
4. Sobald das Update abgeschlossen ist, wird Ihr Gerät automatisch neu gestartet.

Deutsch

SMART HJC 11BC KC Certification Information



Certification Number : R-R-M2v-11Be

Product Name : Bluetooth for motorcycle helmets

Model Name : 11Be

Manufacturer/Country of Origin : MtekVision Co., Ltd. / Korea

Distributor : HJC Corporation Cp., Led.

Domestic and international certification information



CE
(EU)



UKC
(UK)



FCC
(USA)



IC
(CAN)



KC
(KOR)

HJC Corporation

HJC Bldg, 1002, Yangjae-daero, Songpa-gu,
Seoul, 05708 Seoul, Republic of Korea
www.hjchelmets.com



HJC Europe

1 Rue BENJAMIN SILLIMAN JR, 67116
REICHSSTETT, FRANCE

Manufacturer

MtekVision Co., Ltd.
Room 333, 42, Changeop-ro, Sujeong-gu,
Seongnam-si, Gyeonggi-do, Republic of Korea
www.mtekvision.com

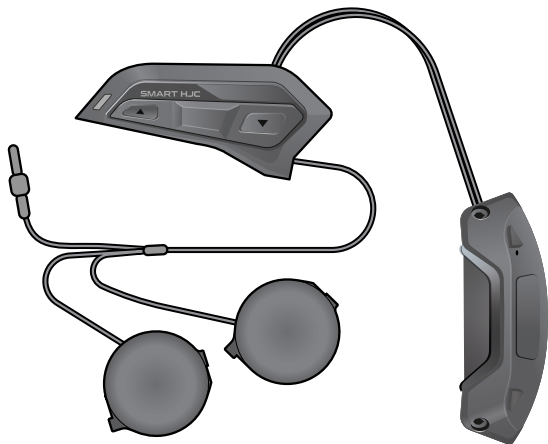

SMART HJC

11Be

Sistema di comunicazione Bluetooth
per caschi HJC

Guida utente
Italiano/Versione 1.0.0



Sommario

| | | |
|----------|--|-----------|
| 1 | Prodotti in sintesi | 5 |
| 1.1 | Contenuto della confezione SMART HJC 11Be | 5 |
| 1.2 | Dettagli del prodotto | 6 |
| 2 | Installazione di 11Be sul tuo casco | 7 |
| 2.1 | Rimozione delle coperture del modulo casco sinistro/destro | 7 |
| 2.2 | Rimozione della copertura del modulo posteriore del casco | 7 |
| 2.3 | Rimozione dell'imbottitura del casco | 7 |
| 2.4 | Installazione del modulo BMS | 8 |
| 2.5 | Installazione del modulo Bluetooth | 9 |
| 2.6 | Installazione di microfono ad asta per caschi jet e caschi modulari | 10 |
| 2.7 | Microfono con velcro a filo e installazione altoparlante sinistro per caschi integrali | 11 |
| 2.8 | Installazione dell'altoparlante destro | 12 |
| 3 | Introduzione a 11Be | 13 |
| 3.1 | Accendi il dispositivo | 13 |
| 3.2 | Spegnere il dispositivo | 13 |
| 3.3 | Verrà riprodotto l'annuncio di spegnimento e il dispositivo verrà spento | 13 |
| 4 | Alimentazione - Standby e ricarica e batteria esterna | 14 |
| 4.1 | Il modulo Bluetooth entra in modalità standby | 14 |
| 4.2 | Ricarica del prodotto | 14 |
| 4.3 | Funzionamento con batteria esterna (in fase di ricarica) | 14 |
| 4.4 | Ripristino delle impostazioni di fabbrica Bluetooth | 14 |
| 5 | Modifica la guida vocale del tuo dispositivo tramite l'app mobile | 15 |
| 6 | Aggiorna il firmware tramite l'app mobile | 16 |
| 7 | Guida alla procedura di ricarica della batteria | 17 |
| 8 | Utilizzo della funzione telefono e della funzione di controllo del volume | 18 |

Sommario

| | | |
|-----------|---|-----------|
| 9 | Utilizzo della funzione di ascolto della musica | 18 |
| 10 | Avvia l'associazione del telefono in modalità di impostazione Bluetooth | 19 |
| | 10.1 Avvia/termina la modalità di impostazione Bluetooth | 19 |
| | 10.2 Associazione del telefono in modalità di impostazione Bluetooth | 19 |
| 11 | Avvia l'associazione dell'interfono in modalità di impostazione Bluetooth | 20 |
| | 11.1 Avvia l'associazione dell'interfono in modalità di impostazione Bluetooth | 20 |
| 12 | Connessione a un interfono con un amico | 21 |
| | 12.1 Dispositivo di associazione 1 Connessione interfono | 21 |
| | 12.2 Dispositivo di associazione 2 Connessione interfono | 21 |
| | 12.3 Associazione di un terzo dispositivo Connessione interfono | 21 |
| 13 | SMART HJC Intercom mit anderen Geräten verbinden | 22 |
| | 13.1 Ausführen des universellen Intercom-Kopplungsmodus von SMART HJC (50B/21B/11B) | 22 |
| | 13.2 Ausführen des SMART HJC (11Be) Intercom-Kopplungsmodus | 22 |
| 14 | Scarica l'app mobile per smartphone | 23 |
| | 14.1 Scarica la nostra app mobile dedicata | 23 |
| | 14.2 Applicazione mobile OTA (over-the-air) | 23 |
| 15 | Introduzione all'app mobile 1 | 24 |
| 16 | Introduzione all'app mobile 2 | 25 |
| | 16.1 Accensione | 25 |
| | 16.2 Spegnimento | 25 |
| | 16.3 Associazione automatica del telefono | 25 |
| | 16.4 Impostazioni Bluetooth > Associazione telefono | 25 |

Sommario

| | | |
|-----------|--|-----------|
| 17 | Introduzione all'app mobile 3 | 26 |
| | 17.1 Impostazioni Bluetooth > Associazione interfono [Connessione amici interfono] | 26 |
| | 17.2 Avvia/termina chiamata interfono | 26 |
| 18 | Selezione della modalità di funzione | 27 |
| 19 | Bluetooth principale | 28 |
| 20 | Stato di associazione | 29 |
| 21 | Impostazioni audio Bluetooth | 30 |
| 22 | Aggiornamento Bluetooth | 31 |
| 23 | Informazioni di autenticazione | 32 |

Contenuto della confezione SMART HJC 11Be



Casco HJC 11Be SMART



Microfono a braccio cablato per caschi modulari/aperti

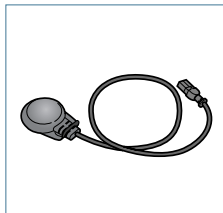

Microfono cablato per casco integrale

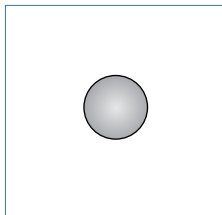

Microfono cablato per casco integrale

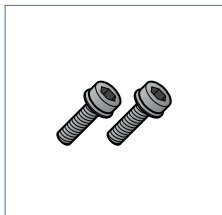

Vite

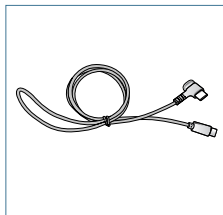

Cavo di ricarica USB (USB C a C)

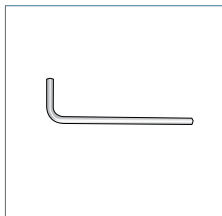

Chiave esagonale

Dettagli del prodotto

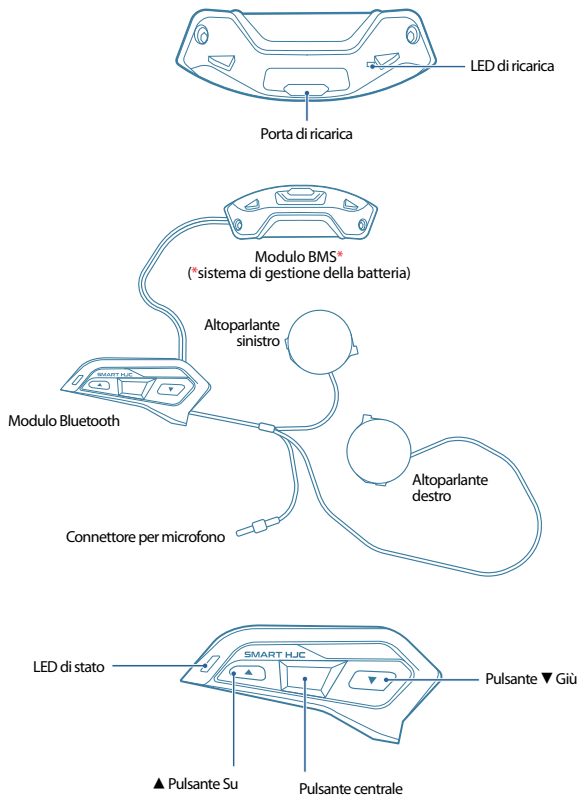

Installazione di 11Be sul tuo casco

Rimozione delle coperture del modulo casco sinistro/destro

Premere la leva di fissaggio sul coperchio sinistro/destro e farla scorrere in un angolo come mostrato nell'immagine seguente per rimuoverlo.

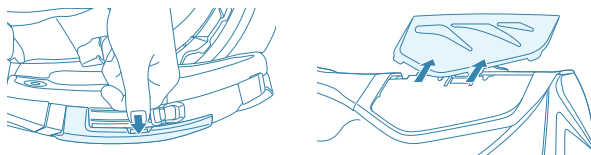

Rimozione della copertura del modulo posteriore del casco

Utilizzare la chiave esagonale fornita per allentare le due viti corte sulla copertura posteriore del casco e rimuovere la copertura.

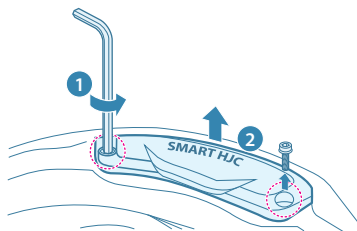

Rimozione dell'imbottitura del casco

Rimuovere la copertura della sede dell'auricolare, rimuovendo precedentemente il guanciaie.

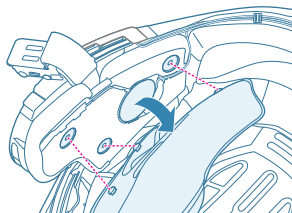

Installazione del modulo BMS

1. Con la porta USB del modulo BMS rivolta verso la parte inferiore del casco, sollevare la protezione in gomma e quindi inserire il modulo BMS. Inserirlo nello slot.

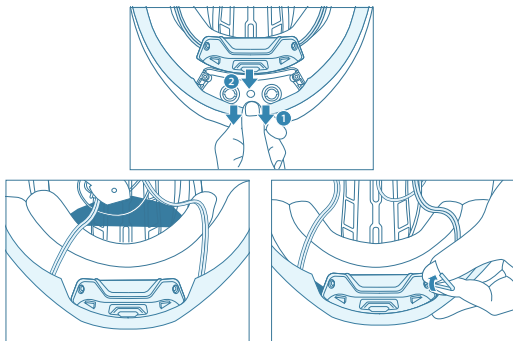

2. Utilizzare i bulloni e la chiave inglese inclusi per fissare il modulo al casco.

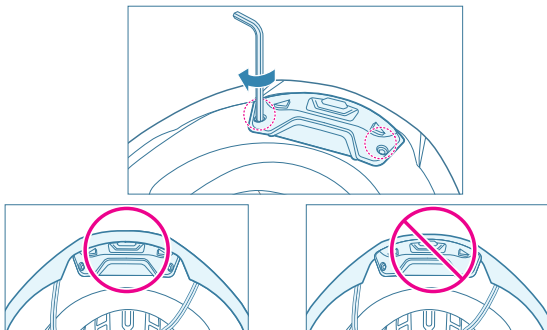

NOTA

La protezione in gomma del casco non deve rimanere intrappolata tra il modulo BMS e la fessura.

Installazione del modulo Bluetooth

1. Controllare le parti di fissaggio nelle immagini superiore e inferiore del modulo Bluetooth.
2. Posizionarlo nella scanalatura di fissaggio del modulo del casco come mostrato nell'immagine e fissarlo spingendolo nella direzione della freccia finché non si sente un clic.
3. Guarda la parte inferiore del casco e controlla se è installato correttamente. (Freccia immagine)

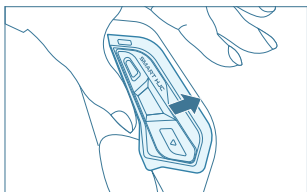
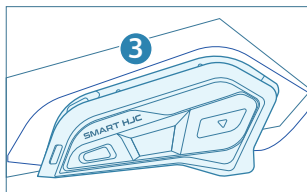
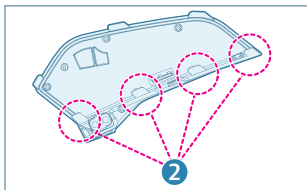
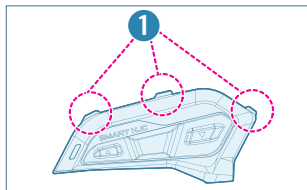

Installazione di microfono ad asta per caschi jet e caschi modulari

1. Posizionare la sporgenza di fissaggio del microfono con asta nella scanalatura dell'EPS del casco.
2. Inserire prima la sporgenza di fissaggio lunga, quindi inserire la sporgenza di fissaggio corta per completare il fissaggio.

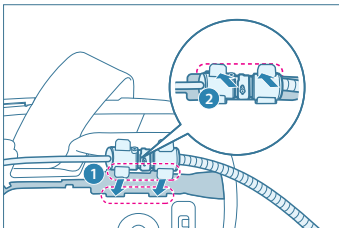

3. Fissare il filo del microfono alla scanalatura EPS del casco e inserire il filo rimanente nella scanalatura di installazione dell'unità altoparlante.

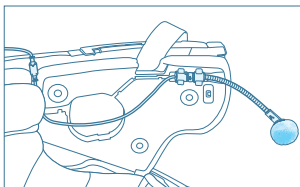
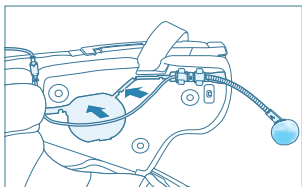

Quando si installa l'unità altoparlante con direzione del microfono, posizionare il filo rimanente del microfono sotto la lunga scanalatura di fissaggio dell'altoparlante, installare la sporgenza di fissaggio dell'altoparlante nella scanalatura di fissaggio EPS del casco e collegarla al connettore del microfono del modulo Bluetooth.

NOTA

Durante l'installazione, assicurarsi che il filo del microfono non venga premuto contro l'altoparlante.

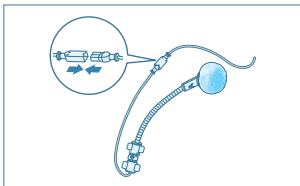
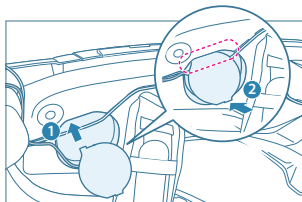

Microfono con velcro a filo e installazione altoparlante sinistro per caschi integrali

1. Rimuovere la copertura del nastro adesivo in velcro per il microfono in dotazione e fissarlo all'interno della mentoniera del casco. Attacca il microfono cablato al nastro in velcro.

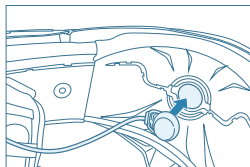
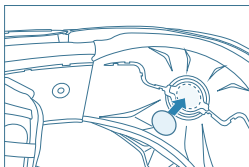
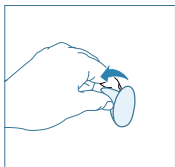

2. Fissare il filo del microfono alla scanalatura EPS del casco e inserire il filo rimanente nella scanalatura di installazione dell'unità altoparlante.

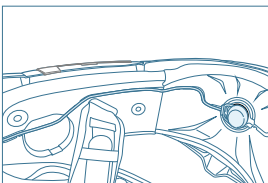
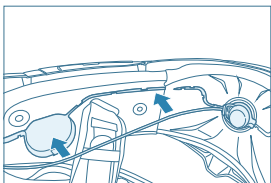

3. Quando si installa l'unità altoparlante sinistra, posizionare il filo rimanente del microfono sotto la lunga scanalatura di fissaggio dell'altoparlante e premere la sporgenza di fissaggio dell'altoparlante. Installalo nella scanalatura di fissaggio dell'EPS del casco e collegalo al connettore del microfono del modulo Bluetooth.

NOTA

Durante l'installazione, assicurarsi che il filo del microfono non venga premuto contro l'altoparlante.

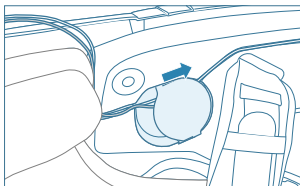
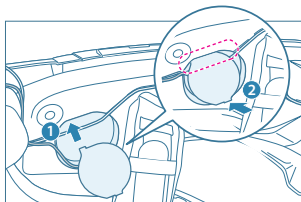

4. Fare riferimento allo schema di collegamento del connettore del microfono nel capitolo precedente.

Installazione dell'altoparlante destro

1. Rimuovere i due bottoni dell'imbottitura superiore del casco.
2. Passare l'altoparlante destro e collegare il cavo attraverso l'interno del materiale del soffitto del casco.
3. Inserire prima la sporgenza di fissaggio lunga dell'altoparlante destro nella scanalatura di fissaggio verso la parte inferiore del casco, quindi inserire la sporgenza di fissaggio corta nella parte superiore del casco. Si prega di inserirlo nella scanalatura di fissaggio direzionale.
4. Fissare un bottone automatico sul lato destro, organizzare il cablaggio, quindi fissare il bottone rimanente.

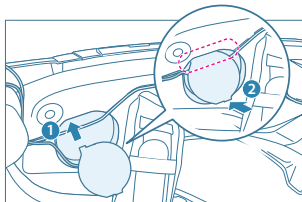

Introduzione a 11Be

Accendi il dispositivo

Premere contemporaneamente il pulsante ▲ Su e il pulsante centrale sul dispositivo per 1,5 secondi fino a sentire un segnale acustico. Verrà riprodotto il messaggio di accensione e il dispositivo si avvierà.

Spegnere il dispositivo

Con il dispositivo acceso, tieni premuti contemporaneamente il pulsante ▲ Su e il pulsante Centrale per 1,5 secondi, finché non senti un segnale acustico.

Verrà riprodotto l'annuncio di spegnimento e il dispositivo verrà spento.

Associazione automatica del telefono

Quando accendi il dispositivo dopo averlo acquistato per la prima volta, entrerà automaticamente in modalità di associazione al telefono. Cerca il dispositivo utilizzando la barra di ricerca Bluetooth nel menu delle impostazioni del telefono e connettilo. (Premendo due volte il pulsante ▼ giù mentre sei in modalità di associazione del telefono, uscirai dalla modalità.)

LED Bluetooth

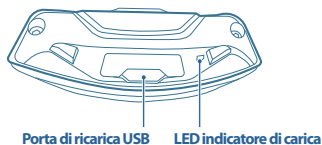
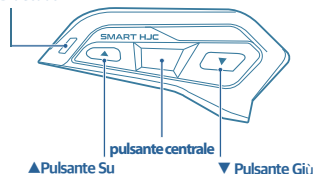



| modalità | Azioni chiave | LED Bluetooth | Guida vocale | Suono bip |
|-------------------------|---|-----------------------|------------------------|-----------|
| Accendere | ▲ + Centro (premere per 1,5 secondi) | /// | Accensione | Bip x 1 |
| Spegnimento | ▲ + Centro (premere per 1,5 secondi) | /// | Spegnimento | Bip x 1 |
| Associazione telefonica | | /// Lampeggio ciclico | Accoppiamento telefono | - |

Alimentazione - Standby e ricarica e batteria esterna

Il modulo Bluetooth entra in modalità standby

1. Dopo 5 minuti di disconnessione tra Bluetooth e smartphone, il modulo Bluetooth si spegnerà automaticamente. A questo punto, anche se la EDR CAM sta registrando, il modulo Bluetooth smetterà di funzionare e si spegnerà.
2. Per utilizzare nuovamente il modulo Bluetooth, accenderlo e ricollegarlo allo smartphone tramite Bluetooth.

Ricarica del prodotto

1. Si ricarica tramite un dispositivo di ricarica USB con ingresso da 5V e supporta il connettore di tipo USB-C.
2. Il LED si illumina () quando il prodotto è in carica / () quando è completamente carico.
3. Spegnerlo il prodotto per ricaricarlo. (Per motivi di sicurezza, la ricarica della batteria non è supportata mentre il prodotto è in funzione.)

Funzionamento con batteria esterna (in fase di ricarica)

Quando è collegata una batteria esterna, il funzionamento del prodotto è supportato e il LED BMS si accende (). (Per motivi di sicurezza, la funzione di monitoraggio intelligente della carica* è attiva quando il prodotto è in funzione.)

*Funzione di monitoraggio della ricarica intelligente

Questa funzione mantiene il livello della batteria del dispositivo costante quando la batteria esterna è collegata, evitando sovraccarichi e sprechi di energia. Funziona quando la batteria esterna è collegata e si disattiva automaticamente quando la batteria esterna viene rimossa.

Ripristino delle impostazioni di fabbrica Bluetooth

Verrà inizializzato con le impostazioni al momento dell'acquisto del prodotto.

(Premere il pulsante centrale per 10 secondi)

Modifica la guida vocale del tuo dispositivo tramite l'app mobile

Al momento della spedizione dalla fabbrica, la guida vocale del dispositivo è impostata in inglese. Puoi cambiare la lingua del dispositivo desiderato tramite l'app mobile.

NOTA

1. Questa funzione può essere eseguita solo quando lo smartphone e il dispositivo sono connessi tramite Bluetooth.
2. Questa funzione può essere eseguita solo quando il dispositivo è acceso o ha un livello di batteria pari o superiore a 3.
3. Non spegnere il dispositivo né scollegare il cavo di alimentazione durante il download e l'aggiornamento. Ciò potrebbe causare malfunzionamenti.



Nella finestra Cambia pagina, tocca il pulsante Aggiorna.

Selezione la lingua preferita. Una volta completato il download sul tuo dispositivo, quest'ultimo si riavvierà.

Lingue supportate : coreano / inglese / francese / tedesco / italiano / spagnolo

Aggiorna il firmware tramite l'app mobile

È possibile aggiornare il firmware Bluetooth tramite l'app mobile.

Se il firmware incluso nell'app mobile e la versione del firmware del dispositivo sono diversi, verrà visualizzato un messaggio di aggiornamento firmware nella schermata principale Bluetooth dell'app mobile e nella schermata di aggiornamento. (Tuttavia, se il firmware del dispositivo è la versione più recente, la richiesta di aggiornamento non verrà visualizzata.)

NOTA

1. Aggiorna l'app mobile per avere sempre il firmware più recente.
2. Questa funzione può essere eseguita solo quando lo smartphone e il dispositivo sono connessi tramite Bluetooth.
3. Questa funzione può essere eseguita solo quando il dispositivo è acceso o ha un livello di batteria pari o superiore a 3.
4. Non spegnere il dispositivo né scollegare il cavo di alimentazione durante il download e l'aggiornamento. Ciò potrebbe causare malfunzionamenti.

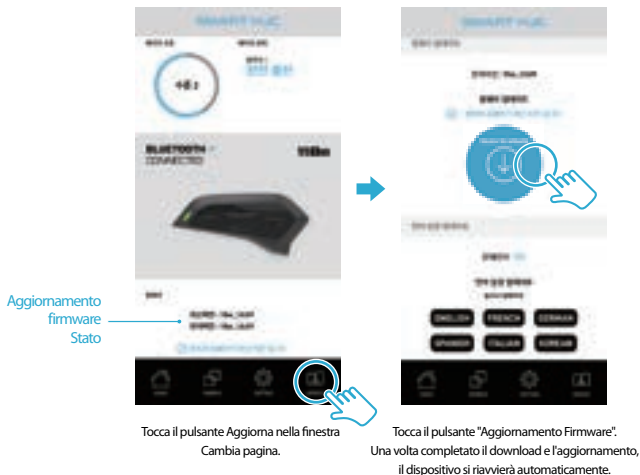

Guida alla procedura di ricarica della batteria

Lo stato di carica della batteria è suddiviso in 4 livelli a partire dal livello 0. Lo stato di carica viene visualizzato sull'app mobile connessa e, se è necessaria la ricarica, all'avvio del dispositivo viene emesso un suono vocale di NOTA di ricarica.



Guida allo stato di carica Bluetooth

| Livello | Stato di carica Bluetooth | Guida vocale |
|---------|---------------------------|---------------------|
| Fase 0 | Batteria BT scarica | Batteria BT scarica |
| Fase 1 | normale | - |
| Fase 2 | Completamente carico | - |
| Fase 3 | | |
| Fase 4 | | |

Utilizzo della funzione telefono e della funzione di controllo del volume

| modalità | Azioni chiave | LED Bluetooth | Guida vocale | Guida vocale |
|---|-------------------------------|------------------|--------------|--------------|
| Il telefono squilla | - | /// Lampeggiante | - | - |
| Rispondere al telefono | Centro (premere una volta) | /// | - | Bip x 1 |
| Rifiutare la chiamata | Centro (doppia pressione) | /// | - | Bip x 1 |
| Riattaccare [durante una chiamata] - | Centro (doppia pressione) | /// | - | Bip x 1 |
| Alza il volume delle cuffie | ▲ (premere una volta) | | - | Bip x 1 |
| Abbassa il volume delle cuffie | ▼ (premi una volta) | | - | Bip x 1 |

**Aumentare il volume
(premere una volta)**

**Abbassare il volume
(premere una volta)**

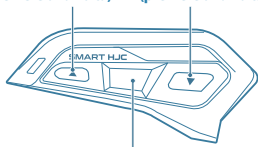

**Riproduci musica (tieni premuto per 1 secondo)
Metti in pausa la musica (tieni premuto per 1 secondo)**

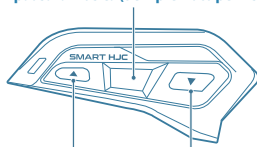

**Rispondere a una chiamata (premere una volta)
Rifiuta chiamata (doppia pressione)
Riagganciare (doppia pressione)**

**Canzone successiva
(tieni premuto
per 1 secondo)**

**Brano precedente
(tieni premuto
per 1 secondo)**

Utilizzo della funzione di ascolto della musica

| modalità | Azioni chiave | LED Bluetooth | Guida vocale | Suono bip |
|----------------------|-----------------------------------|---------------|--------------|-----------|
| Riproduci musica | Centro (premere per 1 secondo) | /// | - | Bip x 1 |
| arresto della musica | Centro (premere per 1 secondo) | /// | - | Bip x 1 |
| Canzone successiva | ▲ (premere per 1 secondo) | /// | - | Bip x 1 |
| Canzone precedente | ▼ (premere per 1 secondo) | /// | - | Bip x 1 |

Avvia l'associazione del telefono in modalità di impostazione Bluetooth

L'associazione del telefono e l'associazione dell'interfono possono essere eseguite nella modalità di impostazione Bluetooth.

Avvia/termina la modalità di impostazione Bluetooth

▼ Premere contemporaneamente il pulsante giù e il pulsante centrale per 1 secondo per accedere alla "Modalità di impostazione Bluetooth".

1. Premendo due volte il [Pulsante Centrale] durante la modalità di impostazione Bluetooth, la modalità verrà interrotta.
2. Una volta completate le impostazioni di associazione, la modalità di impostazione Bluetooth terminerà automaticamente.
3. Se le impostazioni di associazione non vengono completate nella modalità di impostazione Bluetooth, la modalità terminerà automaticamente dopo 10 secondi.

Associazione del telefono in modalità di impostazione Bluetooth

In modalità di impostazione Bluetooth, premendo una volta il pulsante ▼ verso il basso verrà avviato un nuovo "Associazione telefono". L'associazione esistente del telefono verrà ripristinata e lo stato verrà visualizzato tramite un annuncio e un LED. (Vedi la tabella dello stato di associazione qui sotto)



| modalità | Azioni chiave | LED Bluetooth | Guida vocale | Suono bip |
|---------------------------------------|----------------------------------|-----------------------|-------------------------|---------------------|
| Modalità di impostazione Bluetooth | ▼+Centro (premere per 1 secondo) | /// | Impostazioni BT | Segnale acustico x1 |
| Impostazioni Bluetooth fuori | Centro (doppia pressione) | / | - | Bip x2 |
| Associazione telefonica | ▼ (premi una volta) | /// Lampeggio ciclico | Accoppiamento telefono | - |
| Abbinamento interfono* | ▲ (premere una volta) | /// Lampeggio ciclico | Accoppiamento interfono | - |
| Annulla l'associazione del telefono | ▼ (doppia pressione) | / | Accoppiamento annullato | - |
| Annulla l'associazione dell'interfono | ▲ (doppia pressione) | / | Accoppiamento annullato | - |

Associazione interfono*: le istruzioni per connettersi e utilizzare l'interfono con un amico associato sono riportate a pagina 20.

Avvia l'associazione dell'interfono in modalità di impostazione Bluetooth

Quando tu e il dispositivo del tuo amico avviate insieme l'associazione, i dispositivi si assoceranno e si conatteranno automaticamente. Dopo l'associazione, potrai effettuare chiamate interfoniche.

1. Accedere alle impostazioni Bluetooth.
2. Nelle impostazioni Bluetooth, premere una volta il pulsante ▲ Su. Lo stato viene visualizzato con un messaggio guida e un LED. (Fare riferimento alla tabella dello stato di associazione sopra)
3. Il dispositivo può essere associato a un massimo di 3 amici e ricorda le informazioni di associazione anche quando è spento.
4. Se registri un secondo abbinamento di amici mentre il primo amico è registrato,
 - Il primo dispositivo di associazione registrato diventa il dispositivo 2, mentre il secondo amico registrato diventa il dispositivo 1.
 - Allo stesso modo, quando un terzo amico viene registrato per l'associazione, il terzo amico registrato diventa il dispositivo numero 1.
 - L'amico che si è registrato per secondo avrà il dispositivo numero 2, mentre l'amico che si è registrato per primo avrà il dispositivo numero 3.

NOTA

1. Per connetterti a un interfono, devi eseguire le seguenti azioni con il dispositivo del tuo amico a distanza ravvicinata.
2. L'associazione interfono consente la registrazione di un massimo di 3 amici e la comunicazione interfono è possibile solo 1:1.

Connessione a un interfono con un amico

Gli amici registrati per l'abbinamento interfono sul dispositivo manterranno le loro informazioni di registrazione salvate sul dispositivo anche quando questo è spento. Accendete il dispositivo e utilizzatelo seguendo l'ordine di connessione riportato di seguito con l'amico registrato.

Dispositivo di associazione 1 Connessione interfono

1. Premere una volta il [Pulsante Centrale] sul dispositivo che si desidera connettere per accedere alla modalità di connessione interfono. Si sentirà un tono di linea dal dispositivo.
2. Il dispositivo ricevente dell'interfono verrà avvisato con un tono di ricezione e il destinatario completerà la connessione interfono e inizierà la chiamata premendo una volta il pulsante centrale.
3. Durante una chiamata interfono, premere due volte il [Pulsante centrale] per terminare la chiamata interfono.

Dispositivo di associazione 2 Connessione interfono

Tocca due volte il [Pulsante Centrale] sul dispositivo che desideri connettere per accedere alla modalità di connessione interfono. La procedura per connettere i dispositivi è la stessa della connessione all'interfono sul dispositivo 1.

Associazione di un terzo dispositivo Connessione interfono

Premere tre volte il [Pulsante Centrale] sul dispositivo che si desidera connettere per accedere alla modalità di connessione interfono. La procedura per connettere i dispositivi è la stessa della connessione interfono sul dispositivo 1.

L'ultimo dispositivo associato diventa il dispositivo 1 e le informazioni di connessione vengono salvate in ordine inverso.



SMART HJC Collegamento dell'interfono con altri dispositivi

È possibile stabilire una connessione interfono con il prodotto (11Be) impostando il prodotto SMART HJC (50B / 21B / 11B) in modalità di associazione interfono universale. È inoltre possibile stabilire una connessione interfono con il prodotto SMART HJC (10B / 20B) e SENA tramite l'impostazione Modalità universale.

NOTA

La connessione è possibile se l'auricolare Bluetooth SMART HJC supporta Bluetooth HFP (Hands-Free Profile).

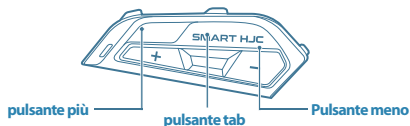

Reparto UI SMART HJC (50B / 21B / 11B)

Esecuzione della modalità di associazione interfono universale SMART HJC (50B / 21B / 11B)

1. Tenere premuto il tasto Tab per 10 secondi [Verrà riprodotto l'annuncio del menu Impostazioni]
2. Premere il pulsante meno 3 volte [Si sentirà l'annuncio di associazione dell'interfono universale]
3. Premere una volta il pulsante Tab [Entra nella modalità di associazione interfono universale]

Esecuzione della modalità di associazione interfono SMART HJC (11Be)

1. Premere contemporaneamente il pulsante centrale e il pulsante ▼ giù per accedere alla modalità "Impostazioni Bluetooth".
2. In modalità "Impostazione Bluetooth", premere il pulsante ▲ Su per accedere alla modalità di associazione interfono.

Quando i dispositivi SMART HJC (50B / 21B / 11B) e (11Be) entrano contemporaneamente in modalità di associazione, viene automaticamente stabilita una connessione interfono e sono possibili chiamate.



Sezione interfaccia utente SMART HJC (11Be)

Scarica l'app mobile per smartphone

Scarica la nostra app mobile dedicata

Cerca "SMART HJC BT (11BC / 11Be)" nel "Google Play Store" per telefoni Android o nell'"App Store" per iPhone, oppure scarica l'app mobile utilizzando il codice QR qui sotto.



Android AOS
Google Play Store



Apple iOS
App Store



Applicazione mobile OTA (over-the-air)

1. È possibile scaricare il firmware più recente tramite la funzione Bluetooth OTA.
2. È possibile scaricare più lingue di guida vocale tramite la funzione Bluetooth OTA.

NOTA

Per un continuo miglioramento della qualità, è possibile che vengano apportati miglioramenti alle prestazioni del dispositivo e aggiornamenti delle funzioni senza preNOTA.

Introduzione all'app mobile 1

1. Scarica e installa l'app mobile dall'App Store.
2. Associa il dispositivo nelle impostazioni Bluetooth del tuo smartphone.
3. Tocca l'icona dell'app installata per avviarla.
4. Quando appare il pop-up di associazione durante l'esecuzione dell'app, seleziona "Associa" per connetterti al dispositivo Bluetooth.

NOTA

1. Se gli utenti iOS (Apple) non riescono a connettere l'app a un dispositivo Bluetooth, premere il pulsante "Riconnetti" nella schermata di standby dell'app per provare nuovamente ad associare.
2. Gli utenti AOS (Android) verranno automaticamente indirizzati alla schermata principale Bluetooth senza che venga visualizzato un pop-up di richiesta di associazione all'interno dell'app una volta completato l'associazione del dispositivo nelle impostazioni Bluetooth dello smartphone.

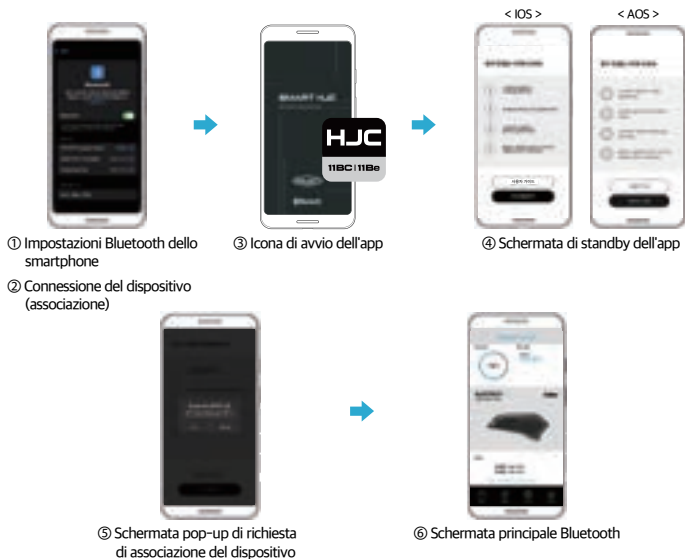

Introduzione all'app mobile 2



Accendi

Tieni premuti contemporaneamente il pulsante ▲ (Su) e il pulsante centrale sul dispositivo per 1,5 secondi finché non senti un segnale acustico. Sentirai la guida vocale "Accensione" e il dispositivo si avvierà.

Spegnimento

Con il dispositivo acceso, tieni premuti contemporaneamente il pulsante ▲ (Su) e il pulsante centrale per 1,5 secondi finché non senti un segnale acustico. Sentirai un messaggio vocale che dice "Spegni" e il dispositivo si spegnerà.

Associazione automatica del telefono

Quando acquisti il dispositivo e lo accendi per la prima volta, entra automaticamente in modalità di associazione con il telefono. Cerca il dispositivo nelle impostazioni Bluetooth del tuo smartphone e connettilo. (Se si preme due volte il pulsante ▼ (giù) durante la modalità di associazione del telefono, la modalità verrà interrotta.)



Impostazioni Bluetooth > Associazione telefono

PASSO 1

Dopo aver acceso l'alimentazione, premere contemporaneamente il pulsante centrale + il pulsante ▼ (giù) per 1 secondo. Il dispositivo entrerà in modalità di impostazione Bluetooth emettendo un segnale acustico e inizierà la guida vocale "Impostazione Bluetooth".

PASSO 2

Nella modalità di impostazione Bluetooth, premendo una volta il pulsante ▼ (giù) si avvia l'"Associazione telefono". La connessione esistente verrà automaticamente interrotta e il dispositivo appena associato si conatterà al telefono.

Annulla l'associazione del telefono

In modalità di associazione del telefono, toccando due volte il pulsante ▼ (giù) si passerà alla modalità "Annulla associazione". Quindi, rizelezionare il dispositivo nelle impostazioni Bluetooth dello smartphone.



Impostazioni Bluetooth > Associazione interfono [Connessione amici interfono]

PASSO 1

Dopo aver acceso entrambi i dispositivi, tieni premuti contemporaneamente il pulsante centrale e il pulsante ▼ (giù) su ciascun dispositivo per 1 secondo. Quando senti un segnale acustico e sei entrato in modalità di configurazione Bluetooth, premi una volta il pulsante ▲ (su) su ciascun dispositivo. Sentirai il messaggio vocale "Abbinamento interfono". Dei segnali acustici ripetuti indicheranno il processo di accoppiamento e l'altro dispositivo cercherà automaticamente l'altro dispositivo.

PASSO 2

Dopo la guida vocale "Intercom Pairing", i due dispositivi si conetteranno automaticamente alla comunicazione interfono.

Annulla l'associazione dell'interfono

In modalità di associazione interfono, premendo due volte il pulsante ▲ (Su) si passerà alla modalità "Annulla associazione".



Avvia/termina chiamata interfono

Per richiamare un amico recentemente abbinato, premere una volta il pulsante centrale. L'interfono si collegherà automaticamente emettendo un segnale acustico da entrambi i dispositivi. Durante una chiamata interfono, se il destinatario o il chiamante premono due volte il pulsante centrale, la connessione interfono verrà interrotta.

NOTA

1. Puoi registrare fino a 3 amici per l'interfono. Come comunicare con 3 amici
Fare riferimento a "page 21" della Guida per l'utente.
2. La registrazione dell'amico interfono riesce solo quando i due dispositivi sono molto vicini tra loro.

Selezione della modalità di funzione



① Seleziona la modalità Bluetooth

Una volta associati il dispositivo e l'app mobile, verrà visualizzato un pulsante per accedere alla schermata principale Bluetooth.

② Guida per l'utente

È possibile visualizzare il manuale utente.

③ Video di avvio rapido

È possibile vedere un video in cui viene montato su un casco.

Bluetooth principale



① Stato del livello della batteria

② Ricarica Bluetooth

③ Nome del modello

④ Controlla il firmware più recente

Se il firmware del tuo dispositivo non è aggiornato, verrà visualizzato un messaggio di avviso rosso.

⑤ Schermata iniziale

Andare alla schermata Selezione modalità funzione.

⑥ Stato di associazione

È possibile controllare lo stato di associazione Bluetooth e interfono e modificare il nome del dispositivo associato.

⑦ Impostazioni audio Bluetooth

Puoi modificare le impostazioni audio Bluetooth.

⑧ Aggiornamento Bluetooth OTA

È possibile aggiornare il firmware Bluetooth e modificare e aggiornare la lingua della guida vocale del dispositivo.

Stato di associazione



① Elenco dei telefoni connessi al mio dispositivo

Verrà visualizzato un elenco dei telefoni attualmente connessi al mio dispositivo tramite Bluetooth. Quando ti connetti per la prima volta, verrà visualizzato il numero Bluetooth univoco del telefono. Tocca quel numero per cambiare il nome, rendendo più facile l'identificazione del dispositivo.

② Elenco degli interfoni collegati al mio dispositivo

Verrà visualizzato un elenco dei dispositivi interfonici attualmente connessi al tuo dispositivo. Quando ti connetti per la prima volta, verrà visualizzato il numero Bluetooth univoco del dispositivo. Tocca quel numero per cambiare il nome, rendendo più facile l'identificazione del dispositivo.

Impostazioni audio Bluetooth



NOTA

1. Dopo aver regolato l'audio sul dispositivo, le impostazioni rimarranno invariate anche se si spegne e si riaccende il dispositivo.
2. Selezionando Ripristina tutte le impostazioni del dispositivo verranno ripristinate ai valori di fabbrica.

Aggiornamento Bluetooth



1 Aggiornamento del firmware Bluetooth richiesto

Quando l'app mobile è connessa al tuo dispositivo, verifica automaticamente la presenza di aggiornamenti e ti invia una notifica.

2 Stato dell'ultimo firmware Bluetooth

Se il tuo dispositivo utilizza il firmware più recente, l'app visualizzerà "Il firmware del tuo dispositivo è l'ultima versione" e potrai utilizzarlo senza un aggiornamento separato.

3 Scarica e modifica la lingua della guida vocale del tuo dispositivo.

Il dispositivo è impostato di fabbrica sulla guida vocale in inglese. Puoi facilmente cambiare la lingua della guida vocale del tuo dispositivo selezionando e scaricando la lingua preferita tramite l'app mobile.

NOTA

1. Mantieni sempre aggiornata la tua app mobile. L'app più recente può gestire e aggiornare in modo affidabile il firmware del tuo dispositivo.
2. L'aggiornamento non verrà eseguito se la batteria del dispositivo non è sufficientemente carica. Verificare il livello della batteria prima di effettuare l'aggiornamento.
3. Se hai collegato il cavo di alimentazione prima dell'aggiornamento, non scolgarlo mai durante l'aggiornamento. Ciò potrebbe causare errori del dispositivo.
4. Una volta completato l'aggiornamento, il dispositivo si riavvierà automaticamente.

Italiano

SMART HJC 11BC KC Certification Information



Certification Number : R-R-M2v-11Be

Product Name : Bluetooth for motorcycle helmets

Model Name : 11Be

Manufacturer/Country of Origin : MtekVision Co., Ltd. / Korea

Distributor : HJC Corporation Cp., Led.

Domestic and international certification information



CE
(EU)



UKC
(UK)



FCC
(USA)



IC
(CAN)



KC
(KOR)

HJC Corporation

HJC Bldg, 1002, Yangjae-daero, Songpa-gu,
Seoul, 05708 Seoul, Republic of Korea
www.hjchelmets.com



HJC Europe

1 Rue BENJAMIN SILLIMAN JR, 67116
REICHSSTETT, FRANCE

Manufacturer

MtekVision Co., Ltd.
Room 333, 42, Changeop-ro, Sujeong-gu,
Seongnam-si, Gyeonggi-do, Republic of Korea
www.mtekvision.com

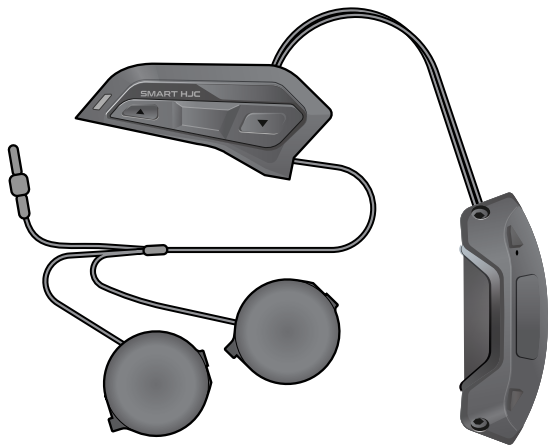

SMART HJC

11Be

Sistema de comunicación Bluetooth
para CASCOS HJC



Guía del usuario
Español/ Versión 1.0.0



Tabla de contenido

| | | |
|----------|---|-----------|
| 1 | Productos de un vistazo | 5 |
| 1.1 | Contenido del paquete SMART HJC 11Be | 5 |
| 1.2 | Detalles del producto | 6 |
| 2 | Instalación de 11Be en tu casco | 7 |
| 2.1 | Extracción de las cubiertas del módulo del casco izquierdo/derecho | 7 |
| 2.2 | Extracción de la cubierta del módulo trasero del casco | 7 |
| 2.3 | Extracción de la almohadilla del casco | 7 |
| 2.4 | Instalación del módulo BMS | 8 |
| 2.5 | Instalación del módulo Bluetooth | 9 |
| 2.6 | Instalación de micrófonos de brazo para cascos abiertos y cascos de sistema | 10 |
| 2.7 | Instalación de micrófono de velcro con cable y altavoz izquierdo para cascos integrales | 11 |
| 2.8 | Instalación del altavoz adecuado | 12 |
| 3 | Empezando con el 11Be | 13 |
| 3.1 | Encienda el dispositivo | 13 |
| 3.2 | Apague el dispositivo | 13 |
| 3.3 | Se reproducirá el anuncio de apagado y el dispositivo se apagará | 13 |
| 4 | Energía - En espera y cargando y batería externa | 14 |
| 4.1 | El módulo Bluetooth entra en modo de espera | 14 |
| 4.2 | Carga del producto | 14 |
| 4.3 | Funcionamiento con batería externa (durante la carga) | 14 |
| 4.4 | Restablecimiento de fábrica de Bluetooth | 14 |
| 5 | Cambie la guía de voz de su dispositivo usando la aplicación móvil | 15 |
| 6 | Actualizar el firmware mediante la aplicación móvil | 16 |
| 7 | Guía de pasos para cargar la batería | 17 |
| 8 | Uso de la función de teléfono y la función de control de volumen | 18 |

Tabla de contenido

| | | |
|-----------|---|-----------|
| 9 | Uso de la función de escuchar música | 18 |
| 10 | Comience a emparejar su teléfono en el modo de configuración de Bluetooth | 19 |
| | 10.1 Iniciar/finalizar el modo de configuración de Bluetooth | 19 |
| | 10.2 Cómo emparejar su teléfono en el modo de configuración de Bluetooth | 19 |
| 11 | Iniciar el emparejamiento del intercomunicador en el modo de configuración de Bluetooth | 20 |
| | 11.1 Iniciar el emparejamiento del intercomunicador en el modo de configuración de Bluetooth | 20 |
| 12 | Conectarse a un intercomunicador con un amigo | 21 |
| | 12.1 Conexión del intercomunicador del dispositivo de emparejamiento 1 | 21 |
| | 12.2 Conexión del intercomunicador del dispositivo de emparejamiento 2 | 21 |
| | 12.3 Emparejamiento de un tercer dispositivo Conexión del intercomunicador | 21 |
| 13 | SMART HJC Conexión del intercomunicador con otros dispositivos | 22 |
| | 13.1 Ejecución del modo de emparejamiento de intercomunicador universal SMART HJC (50B/21B/11B) | 22 |
| | 13.2 Ejecución del modo de emparejamiento del intercomunicador SMART HJC (11Be) | 22 |
| 14 | Descargue la aplicación móvil para teléfonos inteligentes | 23 |
| | 14.1 Descarga nuestra aplicación móvil dedicada | 23 |
| | 14.2 Aplicación móvil OTA (Over-The-Air) | 23 |
| 15 | Introducción a la aplicación móvil 1 | 24 |
| 16 | Introducción a la aplicación móvil 2 | 25 |
| | 16.1 Encendido | 25 |
| | 16.2 Apagado | 25 |
| | 16.3 Emparejamiento automático de teléfonos | 25 |
| | 16.4 Configuración de Bluetooth > Emparejamiento de teléfono | 25 |

Tabla de contenido

| | | |
|-----------|--|-----------|
| 17 | Introducción a la aplicación móvil 3 | 26 |
| 17.1 | Configuración de Bluetooth > Emparejamiento del intercomunicador [Conectar amigos del intercomunicador] | 26 |
| 17.2 | Cancelar el emparejamiento del intercomunicador | 26 |
| 18 | Selección del modo de función | 27 |
| 19 | Bluetooth principal | 28 |
| 20 | Estado de emparejamiento | 29 |
| 21 | Configuración de audio Bluetooth | 30 |
| 22 | Actualización de Bluetooth | 31 |
| 23 | Información de autenticación | 32 |

Contenido del paquete SMART HJC 11Be



SMART HJC 11Be



Micrófono de brazo con cable para cascos modulares/abiertos

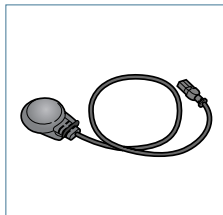

Micrófono con cable para casco integral

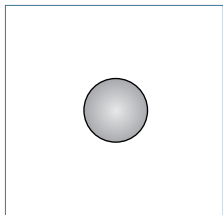

Cinta de velcro para micrófono con cable (suministrada adjunta)

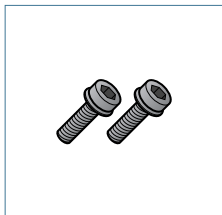

Tornillo

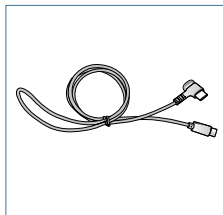

Cable de carga USB (USB C a C)

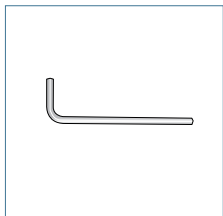

llave hexagonal

Detalles del producto

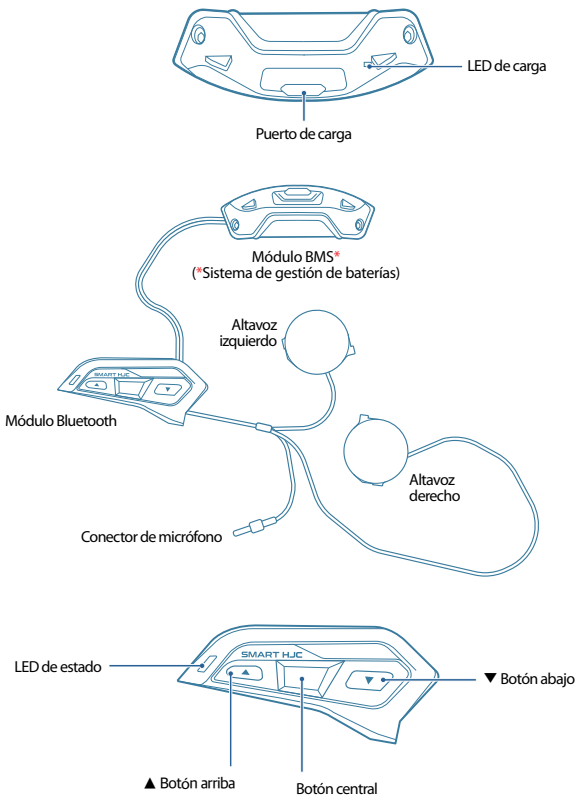

Instalación de 11Be en tu casco

Extracción de las cubiertas del módulo del casco izquierdo/derecho

Presione las palancas de fijación de las cubiertas izquierda/derecha y deslícelas en ángulo como se muestra en la figura siguiente para separarlas.

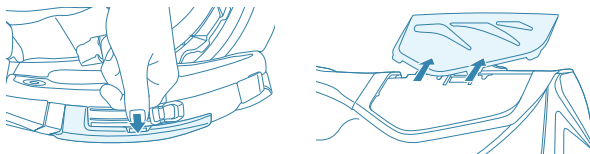

Extracción de la cubierta del módulo trasero del casco

Usando la llave Allen provista, afloje los dos tornillos cortos en la cubierta trasera del casco y retire la cubierta.

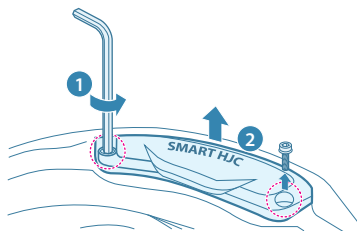

Extracción de la almohadilla del casco

Retire la almohadilla de mejilla del casco quitando los cierres a presión de la almohadilla de la del casco.

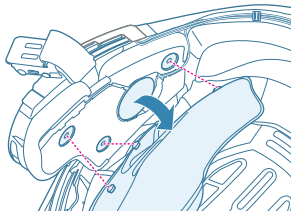

Instalación del módulo BMS

1. Coloque el puerto USB del módulo BMS hacia la parte inferior del casco, levante la protección de goma y luego inserte el módulo BMS. Introdúzcalo en la ranura.

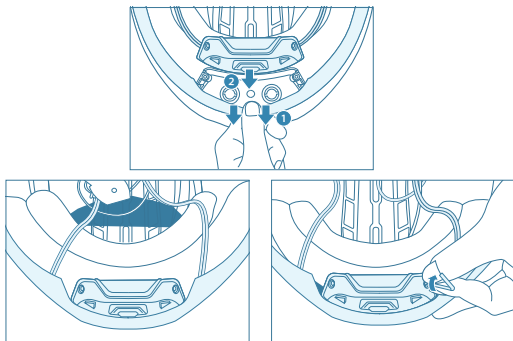

2. Utilice los tornillos y la llave inglesa incluidos para asegurar el módulo al casco.

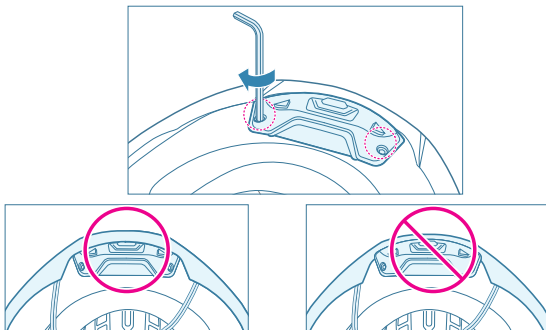

NOTA

Asegúrese de que la protección de goma del casco no quede atrapada entre el módulo BMS y la ranura.

Instalación del módulo Bluetooth

1. Verifique las piezas de fijación de la imagen superior **1** y la imagen inferior **2** del módulo Bluetooth.
2. Colóquelo en la ranura de fijación del módulo del casco como se muestra en la Figura **3** y empújelo en la dirección de la flecha hasta que escuche un clic.
3. Observe la parte inferior del casco y compruebe si está correctamente instalado.
(Figura **4**, flecha)

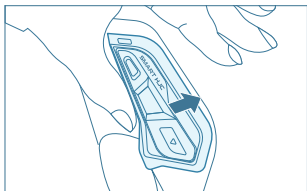
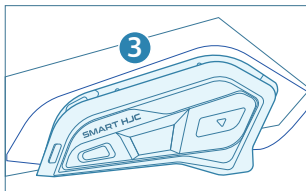
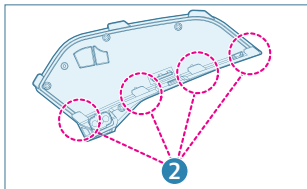
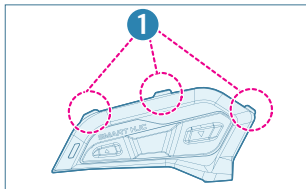

Instalación de micrófonos de brazo para cascos abiertos y cascos de sistema

1. Coloque la orejeta de montaje del micrófono en la ranura del EPS del casco.
2. Inserte primero la protuberancia de fijación larga y luego inserte la protuberancia de fijación corta para completar la fijación.

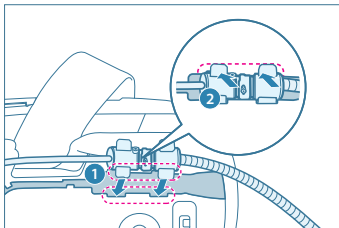

3. Asegure el cable del micrófono en la ranura EPS del casco e inserte el cable restante en la ranura para instalar la unidad del altavoz.

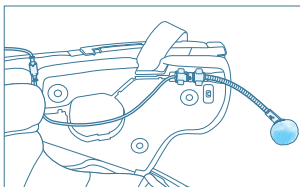
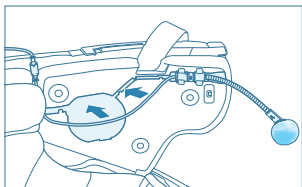

Al instalar la unidad de altavoz de dirección del micrófono, coloque el cable de micrófono restante debajo de la ranura de fijación del altavoz largo, instale la protuberancia de fijación del altavoz en la ranura de fijación EPS del casco y luego conéctelo al conector del micrófono del módulo Bluetooth.

NOTA

Al hacer la instalación, asegúrese de que el cable del micrófono no esté presionado contra la unidad del altavoz.

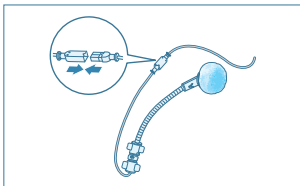
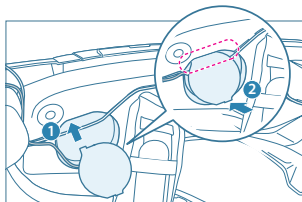

Instalación de micrófono de velcro con cable y altavoz izquierdo para cascos integrales

1. Retire la cubierta de cinta adhesiva del velcro del micrófono incluido, fjela al interior de la protección de la barbilla del casco y luego fije el micrófono con cable a la cinta de velcro.

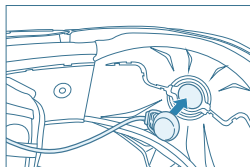
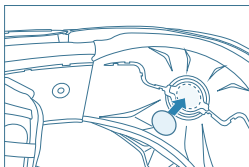
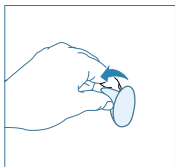

2. Asegure el cable del micrófono en la ranura EPS del casco e inserte el cable restante en la ranura para instalar la unidad del altavoz.

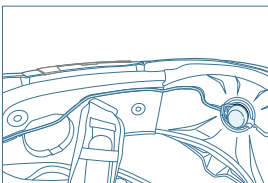
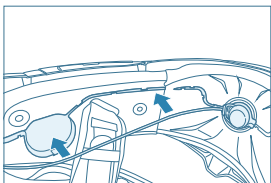

3. Al instalar la unidad de altavoz izquierdo, coloque el cable de micrófono restante debajo de la ranura de fijación del altavoz largo, instale la protuberancia de fijación del altavoz en la ranura de fijación EPS del casco y luego conéctelo al conector del micrófono del módulo Bluetooth.

NOTA

Al hacer la instalación asegúrese de que el cable del micrófono no esté presionado contra la unidad del altavoz.

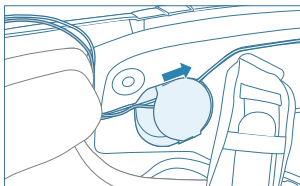
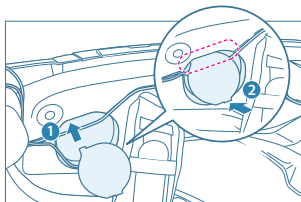

4. Consulte el diagrama de conexión del conector del micrófono en la página anterior.

Instalación del altavoz adecuado

1. Retire los dos broches de presión del revestimiento del techo en la parte trasera del casco.
2. Pase el altavoz derecho y el cable a través del interior del revestimiento del techo del casco.
3. Primero inserte la protuberancia de fijación larga del altavoz derecho en la ranura situada en la parte inferior del casco. Luego, inserte la protuberancia de fijación corta en la parte superior. Asegúrese de que ambas queden bien encajadas en su ranura correspondiente.
4. Fije un broche de presión en el lado derecho del material interior del techo en la parte posterior del casco, organice el cableado y luego fije el cable restante.

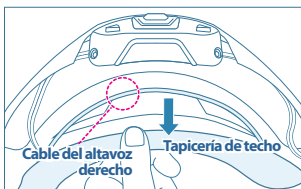
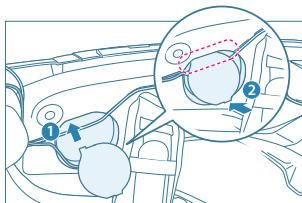

Empezando con el 11Be

Encienda el dispositivo

Presione simultáneamente el botón ▲ Arriba y el botón central del dispositivo durante 1,5 segundos hasta oír un pitido. Se oír el anuncio de encendido y el dispositivo se iniciará.

Apague el dispositivo

Con el dispositivo encendido, mantenga presionado el botón Arriba ▲ y el botón Central simultáneamente durante 1,5 segundos hasta que escuche un pitido.

Se reproducirá el anuncio de apagado y el dispositivo se apagará.

Emparejamiento automático de teléfonos

Cuando encienda el dispositivo después de comprarlo por primera vez, ingresará automáticamente al modo de emparejamiento del teléfono. Busca el dispositivo con la barra de búsqueda de Bluetooth en la configuración del teléfono y conéctalo. (Si presionas dos veces el botón ▼ hacia abajo durante el modo de emparejamiento, saldrás del modo).

LED Bluetooth

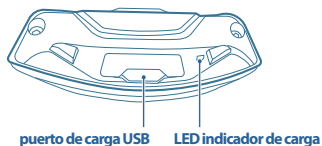
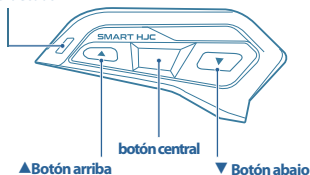



| modo | Acciones clave | LED Bluetooth | Guía de voz | Sonido de confirmación |
|----------------------------|--|--------------------|----------------------------|------------------------|
| Encender | ▲ + Botón central (presione durante 1,5 segundos) | ■ | Encender | Pitido x 1 |
| Apagado | ▲ + Botón central (presione durante 1,5 segundos) | ■ | Apagar | Pitido x 1 |
| Emparejamiento de teléfono | | ■ Parpadeo cíclico | Emparejamiento de teléfono | - |

El módulo Bluetooth entra en modo de espera

1. Tras 5 minutos de desconexión entre el Bluetooth y el smartphone, el módulo Bluetooth se apagará automáticamente. En ese momento, incluso si la EDR CAM está grabando, el módulo Bluetooth dejará de funcionar y se apagará.
2. Para volver a utilizar el módulo Bluetooth, enciéndalo y vuelva a conectarlo a su teléfono inteligente a través de Bluetooth.

Carga del producto

1. Se carga desde un dispositivo de carga USB con entrada de 5 V y admite conector tipo USB-C.
2. El LED se ilumina () cuando el producto se está cargando / () cuando está completamente cargado.
3. Apague el producto para cargarlo. (Por seguridad, no se permite cargar la batería mientras el producto está en funcionamiento).

Funcionamiento con batería externa (durante la carga)

Al conectar una batería externa, el producto funciona correctamente y el LED BMS se ilumina (). (Por seguridad, la función de monitorización de carga inteligente* funciona cuando el producto está en funcionamiento).

*Función de monitor de carga inteligente

Esta función mantiene el nivel de batería del dispositivo cuando la batería externa está conectada, evitando la sobrecarga y el consumo excesivo de energía. Funciona mientras la batería externa está conectada y se desactiva automáticamente al retirarla.

Restablecimiento de fábrica de Bluetooth

Se inicializará con la configuración inicial al comprar el producto.
(Presione el botón central durante 10 segundos)

Cambie la guía de voz de su dispositivo usando la aplicación móvil

Cuando el dispositivo sale de fábrica, su guía de voz está configurada en inglés. Puede cambiar el idioma de su dispositivo deseado usando la aplicación móvil.

NOTA

1. Esta función solo se puede realizar cuando el teléfono inteligente y el dispositivo están conectados a través de Bluetooth.
2. La descarga solo funciona cuando el dispositivo está conectado a la corriente o cuando el nivel de la batería es 3 o superior.
3. No apague el dispositivo ni desconecte el cable de alimentación durante la descarga y la actualización. Esto podría causar un mal funcionamiento.



En la ventana Cambiar página, toque el botón Actualizar.

Seleccione su idioma preferido. Una vez completada la descarga, su dispositivo se reiniciará.

Idiomas admitidos : coreano, inglés, francés, alemán, italiano y español.

Actualizar el firmware mediante la aplicación móvil

Puede actualizar el firmware de Bluetooth mediante la aplicación móvil.

Si el firmware incluido en la aplicación móvil y la versión del dispositivo son diferentes, se mostrará un mensaje de actualización en la pantalla principal de Bluetooth y en la pantalla de actualización. (Sin embargo, si el firmware del dispositivo es la última versión, no se mostrará la solicitud de actualización).

NOTA

1. Actualice su aplicación móvil para mantener el firmware más reciente.
2. Esta función solo se puede realizar cuando el teléfono inteligente y el dispositivo están conectados a través de Bluetooth.
3. Esta función se puede realizar solo cuando el dispositivo está encendido o tiene un nivel de batería 3 o superior.
4. No apague el dispositivo ni desconecte el cable de alimentación durante la descarga y la actualización. Esto podría causar un mal funcionamiento.

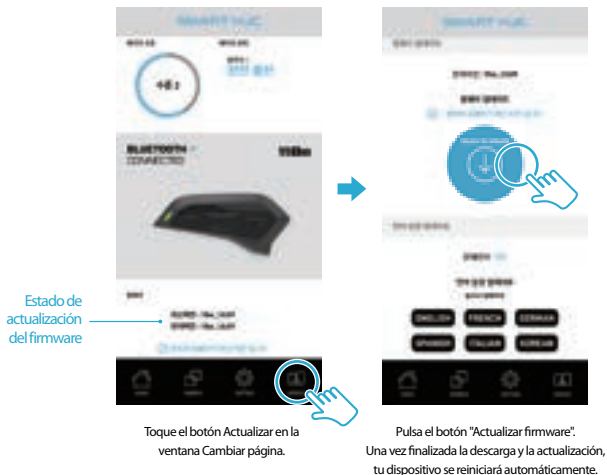

Guía de pasos para cargar la batería

El estado de carga de la batería se divide en 4 niveles desde el nivel 0. El estado de carga se muestra en la aplicación móvil conectada y, si es necesario cargar, se escucha un sonido de guía de voz de advertencia de carga cuando se inicia el dispositivo.



Guía del estado de carga de Bluetooth

| Nivel | Estado de carga de Bluetooth | Guía de voz |
|--------|------------------------------|-----------------|
| Paso 0 | Advertencia de carga | Batería baja BT |
| Paso 1 | normal | - |
| Paso 2 | Completamente cargado | - |
| Paso 3 | | |
| Paso 4 | | |

Uso de la función de teléfono y la función de control de volumen

| modo | Acciones clave | LED Bluetooth | Guía de voz | Sonido de pitido |
|--|-------------------------------------|---------------|-------------|------------------|
| El teléfono suena | - | /// Brillante | - | - |
| Contestar el teléfono | Botón central (presione una vez) | /// | - | Pitido x 1 |
| Rechazar la llamada | Botón central (doble pulsación) | /// | - | Pitido x 1 |
| Colgar [durante una llamada] | Botón central (doble pulsación) | /// | - | Pitido x 1 |
| Subir el volumen de los auriculares | ▲ (presione una vez) | | - | Pitido x 1 |
| Bajar el volumen de los auriculares | ▼ (presione una vez) | | - | Pitido x 1 |

Subir volumen
(presionar una vez) Bajar volumen
(presionar una vez)

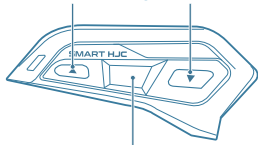

Responder una llamada (presione una vez)
Rechazar llamada (doble pulsación)
Colgar (pulsar dos veces)

Reproducir música (mantener pulsado durante 1 segundo)
Pausa la música (mantén pulsada la tecla durante 1 segundo)

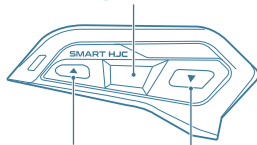

Siguiente canción
(mantener pulsado
1 segundo) Canción anterior
(mantener pulsada durante
1 segundo)

Uso de la función de escuchar música

| modo | Acciones clave | LED Bluetooth | Guía de voz | Sonido de confirmación |
|-------------------|---|---------------|-------------|------------------------|
| Tocar música | Botón central (presione durante 1 segundo) | /// | - | Pitido x 1 |
| parada de música | Botón central (presione durante 1 segundo) | /// | - | Pitido x 1 |
| Siguiente canción | ▲ (presione durante 1 segundo) | /// | - | Pitido x 1 |
| Canción anterior | ▼ (presione durante 1 segundo) | /// | - | Pitido x 1 |

Comience a emparejar su teléfono en el modo de configuración de Bluetooth

El emparejamiento del teléfono y el emparejamiento del intercomunicador se pueden realizar en el modo de configuración de Bluetooth.

Iniciar/finalizar el modo de configuración de Bluetooth

▼ Presione el botón hacia abajo y el botón central simultáneamente durante 1 segundo para ingresar al "Modo de configuración de Bluetooth".

1. Al presionar dos veces el [Botón central] durante el modo de configuración de Bluetooth, se detendrá el modo.
2. Una vez completada la configuración de emparejamiento, el modo de configuración de Bluetooth finalizará automáticamente.
3. Si los ajustes de emparejamiento no se completan en el modo de configuración de Bluetooth, el modo finalizará automáticamente después de 10 segundos.

Cómo emparejar su teléfono en el modo de configuración de Bluetooth

En el modo de configuración de Bluetooth, al presionar el botón ▼ hacia abajo una vez se iniciará un nuevo "Emparejamiento de teléfono". El emparejamiento telefónico se restablecerá y el estado se mostrará mediante un anuncio de guía y una luz LED. (Consulte la tabla de estado de emparejamiento a continuación).

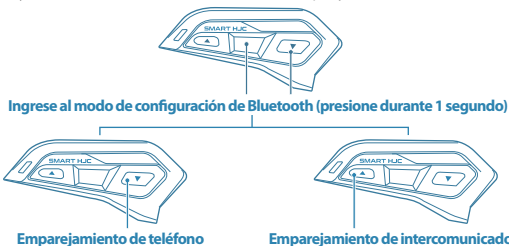

| modo | Acciones clave | LED Bluetooth | Guía de voz | Sonido de confirmación |
|---|--|-----------------------|------------------------------------|------------------------|
| Modo de configuración de Bluetooth | ▼+Botón central (presione durante 1 segundo) | /// | Configuración BT | Pitido x1 |
| Configuración de Bluetooth desactivada | Botón central (doble pulsación) | /// | - | Pitido x2 |
| Emparejamiento de teléfono | ▼ (presione una vez) | /// Parpadeo continuo | Emparejamiento de teléfono | - |
| Emparejamiento de intercomunicador* | ▲ (presione una vez) | /// Parpadeo continuo | Emparejamiento de intercomunicador | - |
| Cancelar el emparejamiento del teléfono | ▼ (pulsar dos veces) | /// | Emparejamiento cancelado | - |
| Cancelar el emparejamiento del intercomunicador | ▲ (pulsar dos veces) | /// | Emparejamiento cancelado | - |

Emparejamiento de intercomunicador*: En la página 20 se explica cómo conectarse y usar el intercomunicador con un amigo emparejado.

Iniciar el emparejamiento del intercomunicador en el modo de configuración de Bluetooth

Cuando tú y el dispositivo de tu amigo inicien el emparejamiento, se conectarán automáticamente. Después del emparejamiento, podrás hacer llamadas por intercomunicador.

1. Ingrese a la configuración de Bluetooth.
2. En la configuración de Bluetooth, pulse el botón ▲ Arriba una vez. El estado se muestra con un mensaje de guía y un LED. (Consulte la tabla de estado de emparejamiento anterior).
3. El dispositivo puede emparejarse con hasta 3 amigos y recuerda la información de emparejamiento incluso cuando el dispositivo está apagado.
4. Si registras un segundo emparejamiento de amigos mientras el primer amigo está registrado,
 - El primer dispositivo de emparejamiento registrado se convierte en el dispositivo 2 y el segundo amigo registrado se convierte en el dispositivo 1.
 - Del mismo modo, cuando un tercer amigo se registra para el emparejamiento, el tercer amigo registrado se convierte en el dispositivo número 1.
 - El amigo que se registró en segundo lugar tendrá el dispositivo número 2, y el amigo que se registró primero tendrá el dispositivo número 3.

NOTA

1. Para conectarse a un intercomunicador, debe realizar las siguientes acciones con el dispositivo de su amigo a corta distancia.
2. El emparejamiento por intercomunicador permite registrar hasta 3 amigos, y la comunicación por intercomunicador solo es posible 1:1.

Conectarse a un intercomunicador con un amigo

Los amigos registrados para emparejarse por intercomunicador en el dispositivo guardarán su información de registro incluso cuando este esté apagado. Encienda el dispositivo y úselo siguiendo el orden de conexión a continuación con el amigo registrado.

Conexión del intercomunicador del dispositivo de emparejamiento 1

1. Pulse el [Botón Central] una vez en el dispositivo que desea conectar para acceder al modo de intercomunicación. Escuchará un tono de marcado.
2. El dispositivo receptor de intercomunicador será notificado con un tono de recepción y el destinatario completará la conexión de intercomunicador y comenzará la llamada presionando el botón central una vez.
3. Durante una llamada de intercomunicador, presione dos veces el [Botón central] para finalizar la llamada de intercomunicador.

Conexión del intercomunicador del dispositivo de emparejamiento 2

Toque dos veces el [Botón Central] en el dispositivo que desea conectar para acceder al modo de intercomunicación. El proceso para conectar dispositivos es el mismo que para conectar el intercomunicador en el dispositivo 1.

Emparejamiento de un tercer dispositivo Conexión del intercomunicador

Presione el [Botón Central] tres veces en el dispositivo que desea conectar para acceder al modo de intercomunicación. El proceso para conectar dispositivos es el mismo que para conectar el intercomunicador en el dispositivo 1.

El último dispositivo emparejado se convierte en el dispositivo 1 y la información de conexión se guarda en orden inverso.



SMART HJC Conexión del intercomunicador con otros dispositivos

Puede establecer una conexión por intercomunicador con el producto (11Be) configurando el SMART HJC (50B/21B/11B) en el modo de emparejamiento universal. También puede establecer una conexión por intercomunicador con el SMART HJC (10B/20B) y el producto SENA mediante el modo universal.

NOTA

La conexión es posible si los auriculares Bluetooth SMART HJC admiten Bluetooth HFP (perfil manos libres).



Departamento de UI SMART HJC (50B / 21B / 11B)

Ejecución del modo de emparejamiento de intercomunicador universal SMART HJC (50B / 21B / 11B)

1. Mantenga presionada la tecla de tabulación durante 10 segundos [Se reproducirá el anuncio del menú de configuración].
2. Presione el botón menos 3 veces [Se escuchará el anuncio de guía de emparejamiento del intercomunicador universal].
3. Presione el botón de tabulación una vez [Ingresar al modo de emparejamiento de intercomunicador universal]

Ejecución del modo de emparejamiento del intercomunicador SMART HJC (11Be)

1. Presione el botón central y el botón ▼ hacia abajo simultáneamente para ingresar al modo "Configuración de Bluetooth".
2. En el modo "Configuración de Bluetooth", presione el botón ▲ Arriba para ingresar al modo de emparejamiento del intercomunicador.

Cuando los dispositivos SMART HJC (50B / 21B / 11B) y (11Be) ingresan al modo de emparejamiento al mismo tiempo, se establece automáticamente una conexión de intercomunicador y son posibles las llamadas.

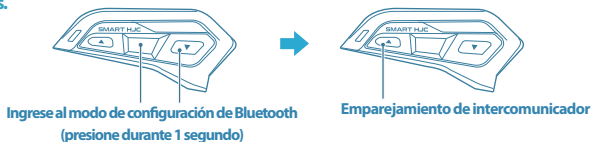

Sección de interfaz de usuario SMART HJC (11Be)

Descargue la aplicación móvil para teléfonos inteligentes

Descarga nuestra aplicación móvil dedicada

Busque "SMART HJC BT (11BC / 11Be)" en "Google Play Store" para teléfonos Android o "App Store" para iPhone, o descargue la aplicación móvil usando el código QR a continuación.

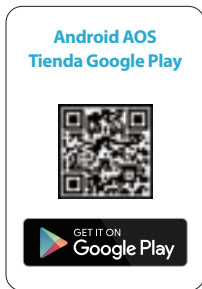

Aplicación móvil OTA (Over-The-Air)

1. Puede descargar el firmware más reciente a través de la función Bluetooth OTA.
2. Puede descargar varios idiomas de guía de voz a través de la función Bluetooth OTA.

NOTA

Para mejorar continuamente la calidad, se pueden realizar mejoras en el rendimiento del dispositivo y actualizaciones de funciones sin previo NOTA.

Introducción a la aplicación móvil 1

1. Descargue e instale la aplicación móvil desde la App Store.
2. Empareje el dispositivo en la configuración Bluetooth de su teléfono inteligente.
3. Toque el icono de la aplicación instalada para iniciarla.
4. Cuando aparezca la ventana emergente de emparejamiento mientras se ejecuta la aplicación, seleccione "Emparejar" para conectarse al dispositivo Bluetooth.

NOTA

1. Si los usuarios de iOS (Apple) no logran conectar la aplicación a un dispositivo Bluetooth, presione el botón "Reconectar" en la pantalla de espera de la aplicación para intentar el emparejamiento nuevamente.
2. Los usuarios de AOS (Android) serán llevados automáticamente a la pantalla principal de Bluetooth sin una ventana emergente de solicitud de emparejamiento dentro de la aplicación después de completar el emparejamiento del dispositivo en la configuración de Bluetooth del teléfono inteligente.



Introducción a la aplicación móvil 2



Encender

Mantenga pulsados simultáneamente los botones ▲ (Arriba) y el botón central del dispositivo durante 1,5 segundos hasta oír un pitido. Escuchará la instrucción de voz "Encendido" y el dispositivo se iniciará.

Apagado

Con el dispositivo encendido, mantenga presionados simultáneamente el botón ▲ (Arriba) y el botón central durante 1,5 segundos hasta que escuche un pitido. Escuchará la instrucción de voz "Apagar" y el dispositivo se apagará.

Emparejamiento automático de teléfonos

Al comprar el dispositivo y encenderlo, este entra automáticamente en modo de emparejamiento. Busca el dispositivo en la configuración de Bluetooth de tu smartphone y conéctalo.

(Si presiona el botón ▼ (abajo) dos veces durante el modo de emparejamiento del teléfono, el modo se detendrá).



Configuración de Bluetooth > Emparejamiento de teléfono

PASO 1

Después de encender, presione el botón central + el botón ▼ (abajo) simultáneamente durante 1 segundo. El dispositivo ingresará al modo de configuración de Bluetooth con un pitido y comenzará la guía de voz de "Configuración de Bluetooth".

PASO 2

En el modo de configuración de Bluetooth, al presionar el botón ▼ (abajo) una vez, se inicia el emparejamiento del teléfono. La conexión existente se desconectará automáticamente y el dispositivo recién emparejado se conectará a su teléfono.

Cancelar el emparejamiento del teléfono

En el modo de emparejamiento telefónico, al pulsar dos veces el botón ▼ (abajo) se cambiará al modo "Cancelar emparejamiento". A continuación, vuelva a seleccionar el dispositivo en la configuración de Bluetooth de su smartphone.

Introducción a la aplicación móvil 3



Configuración de Bluetooth > Emparejamiento de intercomunicador [Conectar amigos de intercomunicador]

PASO 1

Después de encender ambos dispositivos, mantenga presionados simultáneamente el botón central y el botón ▼ (abajo) en cada dispositivo durante 1 segundo. Una vez que escuche un pitido y acceda al modo de configuración de Bluetooth, presione el botón ▲ (arriba) en cada dispositivo una vez. Escuchará el mensaje de voz "Emparejamiento de intercomunicador". Los pitidos repetidos indicarán el proceso de emparejamiento y el otro dispositivo buscará automáticamente al otro.

PASO 2

Después de la guía de voz "Emparejamiento de intercomunicador", los dos dispositivos se conectarán automáticamente a la comunicación por intercomunicador.

Cancelar el emparejamiento del intercomunicador

En el modo de emparejamiento de intercomunicador, al presionar el botón ▲ (Arriba) dos veces cambiará al modo "Cancelar emparejamiento".



Iniciar/finalizar llamada de intercomunicador

Para volver a llamar a un amigo recientemente emparejado, presione el botón central una vez.

El intercomunicador se conectará automáticamente con un pitido de ambos dispositivos.

Durante una llamada de intercomunicador, si el destinatario o la persona que llama presiona dos veces el botón central, la conexión de intercomunicador finalizará.

NOTA

1. Puedes registrar hasta 3 amigos para usar el intercomunicador. Cómo usar el intercomunicador con 3 amigos Consulte la PAGE 21 de la Guía del usuario.
2. El registro de amigos por intercomunicador solo es exitoso cuando los dos dispositivos están muy cerca uno del otro.

Selección del modo de función



① Seleccionar el modo Bluetooth

Una vez que el dispositivo y la aplicación móvil estén emparejados, verá un botón para ingresar a la pantalla principal de Bluetooth.

② Guía del usuario

Puede consultar el manual del usuario.

③ Vídeo de inicio rápido

Puedes ver un vídeo de su montaje en un casco.

Bluetooth principal



① Estado del nivel de batería

② Carga por Bluetooth

③ Nombre del modelo

④ Verifique el firmware más reciente

Si el firmware de su dispositivo no está actualizado, aparecerá un mensaje de advertencia rojo.

⑤ Pantalla de inicio

Vaya a la pantalla de selección del modo de función.

⑥ Estado de emparejamiento

Puede verificar el estado de emparejamiento de Bluetooth y del intercomunicador y editar el nombre del dispositivo emparejado.

⑦ Configuración de audio Bluetooth

Puede cambiar la configuración de audio de Bluetooth.

⑧ Actualización OTA de Bluetooth

Puede actualizar el firmware de Bluetooth y cambiar y actualizar el idioma de la guía de voz de su dispositivo.

Estado de emparejamiento



① Lista de teléfonos conectados a mi dispositivo

Se mostrará una lista de los teléfonos conectados a mi dispositivo por Bluetooth. Al conectarlo por primera vez, se mostrará el número único de Bluetooth del teléfono. Toque ese número para cambiar el nombre y facilitar la identificación del dispositivo.

② Lista de intercomunicadores conectados a mi dispositivo

Se mostrará una lista de los dispositivos de intercomunicación conectados a tu dispositivo. Al conectarte por primera vez, se mostrará el número único de Bluetooth del dispositivo. Pulsa ese número para cambiar el nombre y facilitar su identificación.

Configuración de audio Bluetooth

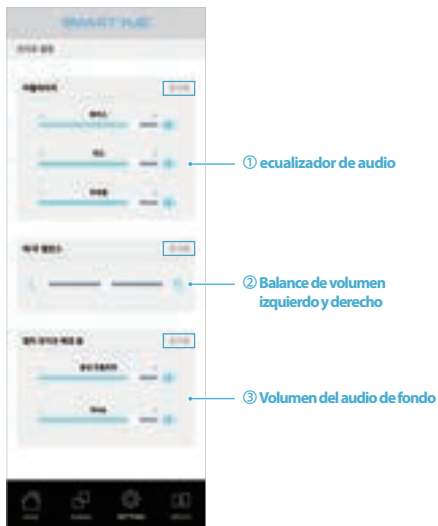

NOTA

1. Después de ajustar el audio en el dispositivo, la configuración permanecerá incluso si apaga el dispositivo y lo vuelve a encender.
2. Seleccionar Restablecer restablecerá todas las configuraciones del dispositivo a sus valores de fábrica.

Actualización de Bluetooth



① Se requiere actualización del firmware de Bluetooth

Cuando la aplicación móvil está conectada a su dispositivo, busca automáticamente actualizaciones y le notifica.

② Estado del firmware más reciente de Bluetooth

Si su dispositivo está usando el firmware más reciente, la aplicación mostrará "El firmware de su dispositivo es la última versión" y podrá usarlo sin una actualización independiente.

③ Descargue y cambie el idioma de la guía de voz de su dispositivo.

El dispositivo viene configurado de fábrica con la guía de voz en inglés. Puede cambiar fácilmente el idioma de la guía de voz seleccionando y descargando su idioma preferido a través de la aplicación móvil.

NOTA

1. Mantén siempre actualizada tu aplicación móvil. La última versión de la aplicación puede gestionar y actualizar el firmware de tu dispositivo de forma fiable.
2. La actualización no se realizará si la batería de su dispositivo no tiene suficiente carga. Verifique el nivel de batería antes de actualizar.
3. Si conectó el cable de alimentación antes de la actualización, nunca lo desconecte durante la misma. Esto podría causar errores en el dispositivo.
4. Una vez completada la actualización, su dispositivo se reiniciará automáticamente.

Español

SMART HJC 11BC

KC Certification Information



Certification Number : R-R-M2v-11Be

Product Name : Bluetooth for motorcycle helmets

Model Name : 11Be

Manufacturer/Country of Origin : MtekVision Co., Ltd. / Korea

Distributor : HJC Corporation Cp., Led.

Domestic and international certification information



CE
(EU)



UKC
(UK)



FCC
(USA)



IC
(CAN)



KC
(KOR)

HJC Corporation

HJC Bldg, 1002, Yangjae-daero, Songpa-gu,
Seoul, 05708 Seoul, Republic of Korea
www.hjchelmets.com



HJC Europe

1 Rue BENJAMIN SILLIMAN JR, 67116
REICHSSTETT, FRANCE

Manufacturer

MtekVision Co., Ltd.
Room 333, 42, Changeop-ro, Sujeong-gu,
Seongnam-si, Gyeonggi-do, Republic of Korea
www.mtekvision.com



SMART HJC

11Be

Bluetooth Communication System
For HJC HELMETS

사용자 가이드
한국어 / 버전 1.0.0



목차

| | |
|--|-----------|
| 1 SMART HJC 11Be 정보 | 5 |
| 1.1 제품의 구성 | 5 |
| 1.2 제품 상세 정보 | 6 |
| 2 헬멧에 11Be 설치하기 | 7 |
| 2.1 헬멧 좌/우측 모듈 커버 제거하기 | 7 |
| 2.2 헬멧 후면 모듈 커버 제거하기 | 7 |
| 2.3 헬멧 칩 패드 분리하기 | 7 |
| 2.4 BMS 모듈 설치 | 8 |
| 2.5 블루투스 모듈 설치 | 9 |
| 2.6 오픈 페이스 헬멧 및 시스템 헬멧을 위한 붐 마이크 설치 | 10 |
| 2.7 풀 페이스 헬멧을 위한 유선 벨크로 마이크와 좌측 스피커 설치 | 11 |
| 2.8 우측 스피커 설치 | 12 |
| 3 11Be 시작하기 | 13 |
| 3.1 기기 전원 켜기 | 13 |
| 3.2 기기 전원 종료하기 | 13 |
| 3.3 자동 폰 페어링 | 13 |
| 4 전원 - 대기모드 & 충전하기 & 외장 배터리 | 14 |
| 4.1 블루투스 모듈 전원대기모드 진입 | 14 |
| 4.2 제품 충전하기 | 14 |
| 4.3 외장 배터리 (충전 시) 동작하기 | 14 |
| 4.4 블루투스 공장초기화 | 14 |
| 5 모바일 앱을 통해 기기 안내 음성 바꾸기 | 15 |
| 6 모바일 앱을 통해 펌웨어 업데이트하기 | 16 |
| 7 배터리 충전 단계 안내 | 17 |
| 8 전화 기능 & 볼륨 조정기능 사용하기 | 18 |

목차

| | | |
|-----------|--|-----------|
| 9 | 음악 듣기 기능 사용하기 | 18 |
| 10 | 블루투스 세팅에서 폰 페어링 시작하기 | 19 |
| 10.1 | 블루투스 세팅 시작 / 종료하기 | 19 |
| 10.2 | 블루투스 세팅 모드에서 폰 페어링 하기 | 19 |
| 11 | 블루투스 세팅에서 인터콤 페어링 시작하기 | 20 |
| 11.1 | 블루투스 세팅 모드에서 인터콤 페어링 시작하기 | 20 |
| 12 | 친구와 인터콤 연결하기 | 21 |
| 12.1 | 페어링 1번 기기 인터콤 연결하기 | 21 |
| 12.2 | 페어링 2번 기기 인터콤 연결하기 | 21 |
| 12.3 | 페어링 3번 기기 인터콤 연결하기 | 21 |
| 13 | SMART HJC 다른 기기와 인터콤 연결하기 | 22 |
| 13.1 | SMART HJC (50B / 21B / 11B) 유니버설 인터콤 페어링 모드 실행하기 | 22 |
| 13.2 | SMART HJC (11Be) 인터콤 페어링 모드 실행하기 | 22 |
| 14 | 스마트폰 모바일앱 다운로드하기 | 23 |
| 14.1 | 전용 모바일앱 다운로드하기 | 23 |
| 14.2 | 모바일앱 OTA(Over-The-Air) | 23 |
| 15 | 모바일앱 시작하기 1 | 24 |
| 16 | 모바일앱 시작하기 2 | 25 |
| 16.1 | 전원 시작 | 25 |
| 16.2 | 전원 종료 | 25 |
| 16.3 | 자동 폰 페어링 | 25 |
| 16.4 | 블루투스 세팅 "폰 페어링" | 25 |

목차

| | |
|--|----|
| 17 모바일앱 시작하기 3 | 26 |
| 17.1 블루투스 세팅 “인터콤 페어링” [친구와 인터콤 연결하는 방법] | 26 |
| 17.2 인터콤 통화 시작 / 종료 | 26 |
| 18 기능 모드 선택 화면 | 27 |
| 19 블루투스 메인 화면 | 28 |
| 20 페어링 상태 화면 | 29 |
| 21 블루투스 오디오 세팅 | 30 |
| 22 블루투스 업데이트 | 31 |
| 23 인증정보 | 32 |

제품의 구성

SMART HJC 11Be 패키지 구성



SMART HJC 11Be



모듈형/오픈 페이스 헬멧용
유선 붐 마이크



풀 페이스 헬멧용
유선 마이크

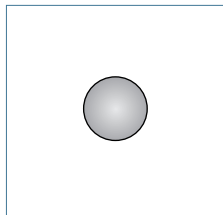

유선 마이크용
벨크로 테이프
(부착되어 제공)

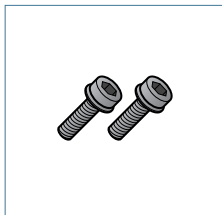

나사

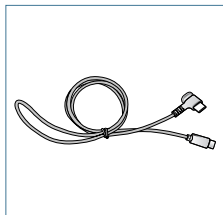

USB 전원 충전 케이블
(USB C to C)

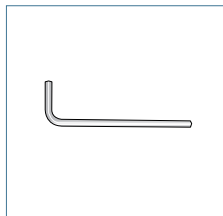

육각렌치

제품 상세 정보

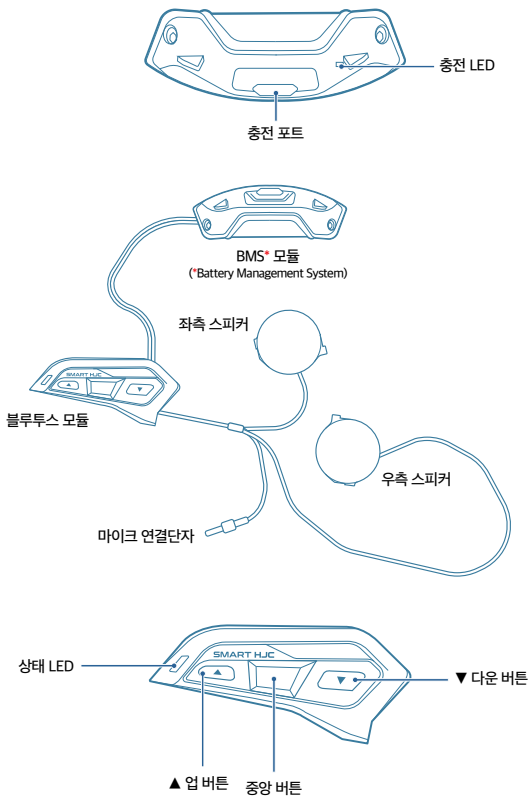

헬멧에 11Be 설치하기

헬멧 좌/우측 모듈 커버 제거하기

좌/우측 커버의 고정 레버를 누르고, 아래 그림의 비스듬한 각도로 밀어서 분리합니다.

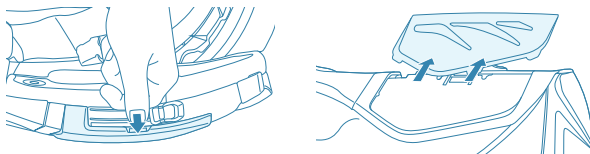

헬멧 후면 모듈 커버 제거하기

제공된 육각렌치로 헬멧 뒤쪽 커버의 짧은 나사 2개를 풀어 커버를 분리합니다.

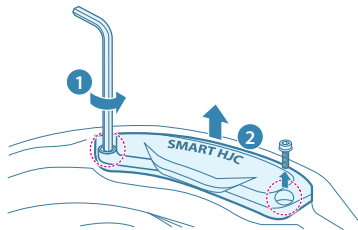

헬멧 칩 패드 분리하기

헬멧에 부착된 칩 패드의 스냅 패스너를 떼어 헬멧에서 칩 패드를 분리합니다.

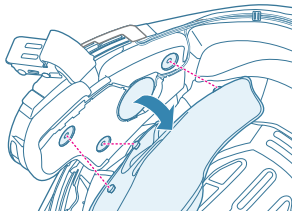

BMS 모듈 설치

1. BMS 모듈의 USB 포트가 헬멧의 아래쪽을 향하게 하고, 고무 가드를 위로 당긴 다음 BMS 모듈을 슬롯에 삽입합니다.

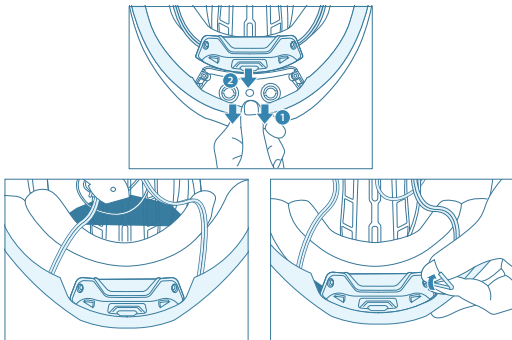

2. 동봉된 렌치 볼트와 렌치 드라이버를 사용하여 모듈을 헬멧에 단단히 고정합니다.

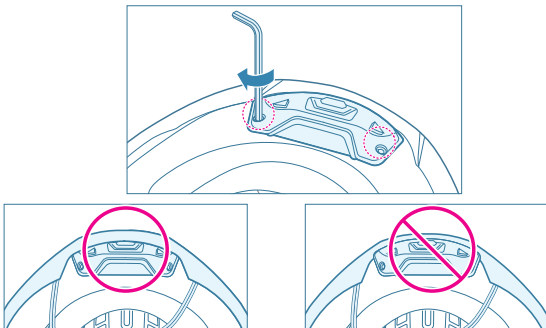

주의 사항

헬멧의 고무 가드가 BMS 모듈과 슬롯 사이에 끼어있지 않아야 합니다.

블루투스 모듈 설치

1. 블루투스 모듈의 상측 그림 ①과 하측 그림 ②의 고정부위를 점검해 주세요.
2. 헬멧의 모듈 고정 홈에 그림 ③과 같이 위치시키고, 화살표 방향으로 딸깍 소리가 들리도록 밀어 고정해 주세요.
3. 헬멧 바닥면을 보고, 정상적인 장착이 되어 있는지 확인합니다. (그림 ④ 화살표)

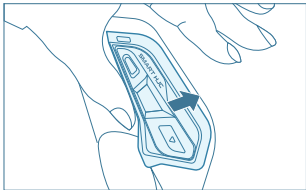
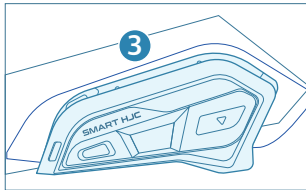
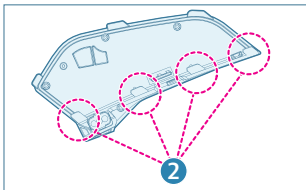
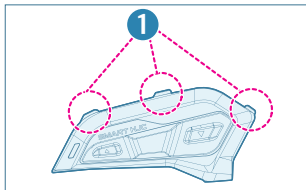

오픈 페이스 헬멧 및 시스템 헬멧을 위한 붐 마이크 설치

1. 붐 마이크의 고정 돌기를 헬멧 EPS에 있는 홈에 위치합니다.
2. 긴 고정 돌기를 먼저 삽입한 후 짧은 고정 돌기를 삽입하여 고정을 마무리합니다.

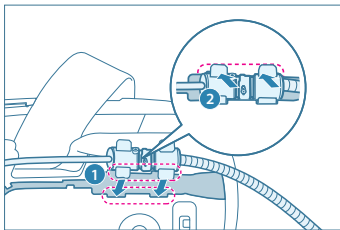

3. 마이크 선을 헬멧 EPS 홈에 고정하며, 남은 선을 스피커 유닛 설치용 홈에 넣습니다.

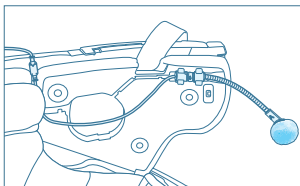
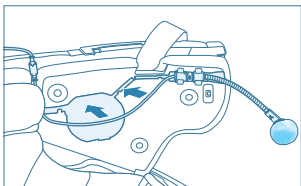

마이크 방향 스피커 유닛 설치 시 남은 마이크 선을 스피커 긴 고정 홈 아래에 위치하고, 스피커 고정 돌기를 헬멧 EPS 고정 홈에 설치 후 블루투스 모듈 마이크 커넥터에 연결합니다.

주의 사항

설치할 때 마이크 선이 스피커 유닛에 눌리지 않도록 해야 합니다.

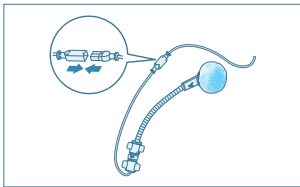
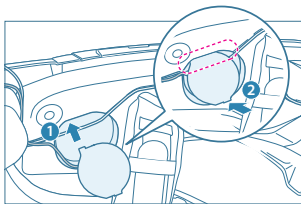

플 페이스 헬멧을 위한 유선 벨크로 마이크와 좌측 스피커 설치

1. 동봉된 마이크용 벨크로 테이프의 접착테이프 커버를 벗긴 후 헬멧의 chin 가드(Chin Guard) 안쪽에 부착 후, 유선 마이크를 벨크로 테이프에 부착합니다.

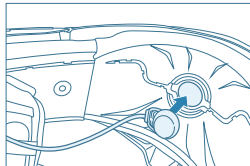
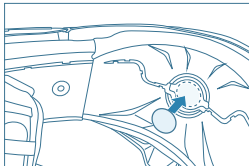
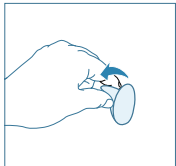

2. 마이크 선을 헬멧 EPS 홈에 고정하며, 남은 선을 스피커 유닛 설치용 홈에 넣습니다.

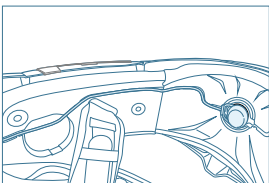
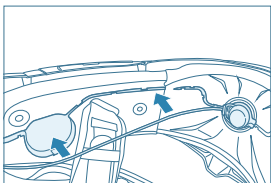

3. 좌측 스피커 유닛 설치 시 남은 마이크 선을 스피커 긴 고정 홈 아래에 위치하고, 스피커 고정 돌기를 헬멧 EPS 고정 홈에 설치 후 블루투스 모듈 마이크 커넥터에 연결합니다.

주의 사항

설치할 때 마이크 선이 스피커 유닛에 눌리지 않도록 해야 합니다.

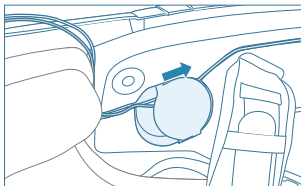
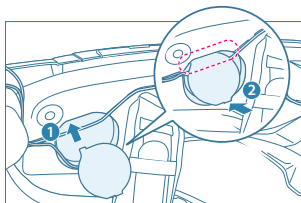

4. 위 장의 마이크 커넥터 연결 그림을 참조하세요.

우측 스피커 설치

1. 헬멧 후면의 천장 내장재 스냅 패스너 2개를 떼어주세요.
2. 우측 스피커와 선을 헬멧 천장 내장재 안쪽으로 통과시켜 주세요.
3. 우측 스피커의 긴 고정 돌기를 먼저 헬멧의 바닥 방향 고정 홈에 삽입 후 짧은 고정 돌기를 헬멧 상측 방향 고정 홈에 삽입해 주세요.
4. 헬멧 후면의 천장 내장재 우측 스냅 패스너 1개를 고정 후 배선 정리 후 나머지 1개를 고정해 주세요.

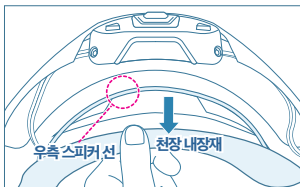
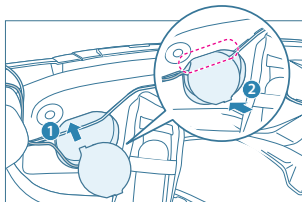

11Be 시작하기

기기 전원 켜기

기기의 ▲ 업 버튼과 중앙 버튼을 동시에 비프음이 나올 때까지 1.5초간 눌러주세요.
Power On 안내방송이 나오며, 기기가 시작됩니다.

기기 전원 종료하기

기기의 전원이 켜진 상태에서 ▲ 업 버튼과 중앙 버튼을 동시에 비프음이 나올 때까지 1.5초간 눌러주세요.
Power Off 안내방송이 나오며, 기기가 종료됩니다.

자동 폰 페어링

기기를 최초 구매하고, 기기의 전원을 켜면 자동으로 폰 페어링 모드에 진입합니다.
폰 설정의 블루투스 검색 창을 통해서 기기를 검색한 후 연결하세요.
(폰 페어링 모드 중 ▼ 다운 버튼을 두번 누르면, 모드가 중단됩니다)

블루투스 LED

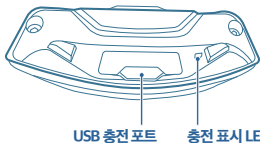
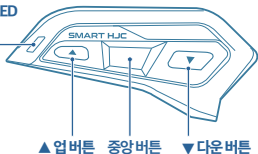



| 모드 | 키 동작 | 블루투스 LED | 음성 안내 | 비프음 |
|-------|-------------------|-----------|-------|-------|
| 파워 온 | ▲ + 중앙 (1.5초간 누름) | / | 파워 온 | 뱃 x 1 |
| 파워 오프 | ▲ + 중앙 (1.5초간 누름) | / | 파워 오프 | 뱃 x 1 |
| 폰 페어링 | | / / 순환 점멸 | 폰 페어링 | - |

전원 - 대기모드 & 충전하기 & 외장 배터리

블루투스 모듈 전원대기모드 진입

1. 블루투스와 스마트폰의 연결이 해제된 후 5분이 지나면, 블루투스 모듈은 자동으로 파워 오프 됩니다.
2. 블루투스 모듈을 다시 사용하려면, 전원을 켜고 스마트폰과 블루투스 연결을 다시 진행해 주세요.

제품 충전하기

1. 5V 입력 USB 충전 기기에서 충전되며, USB-C 타입 커넥터를 지원합니다.
2. LED는 제품 충전 시 () / 완충 시 ()로 점등합니다.
3. 충전을 위해서는 제품의 전원을 종료하여 주시기 바랍니다.
(안전을 위해 제품 동작 시 배터리 충전은 지원하지 않습니다)

외장 배터리 (충전 시) 동작하기

외장 배터리 연결 시 제품 동작을 지원하며, BMS LED는 ()로 점등합니다.
(안전을 위해 제품 동작시 스마트 충전 모니터 기능*이 동작합니다)

*스마트 충전 모니터 기능

이 기능은 외장 배터리 연결 시점의 기기 배터리 잔량을 유지하며 과충전 및 전력 낭비를 방지합니다.
외장 배터리가 연결되어 있는 동안만 작동하며, 분리 시 자동으로 기능이 해제됩니다.

블루투스 공장초기화

제품 구매 시 설정으로 초기화됩니다. (중앙 버튼을 10초간 눌러주세요)

모바일 앱을 통해 기기 안내 음성 바꾸기

공장 출하 시 기기의 음성 안내는 영어로 설정되어 있습니다.
모바일 앱을 통해서 원하는 기기의 언어로 변경할 수 있습니다.

주의 사항

1. 스마트폰과 기기가 블루투스 연결이 되어 있어야만 기능을 수행할 수 있습니다.
2. 기기의 전원이 연결되어 있거나, 배터리 Level 3 이상에서만 다운로드 동작합니다.
3. 다운로드 및 업데이트 중 기기의 전원 종료 혹은 전원 케이블을 빼지 마세요.



페이지 변경 창에서
업데이트 버튼을 탭 해주세요.

원하는 언어를 선택해 주세요.
기기에 다운로드 완료 후
기기는 다시 시작합니다.

지원 언어 : 한국어 / 영어 / 프랑스어 / 독일어 / 이탈리아어 / 스페인어

모바일 앱을 통해 펌웨어 업데이트하기

블루투스 펌웨어를 모바일 앱을 통하여 업데이트할 수 있습니다.

모바일 앱에서 가지고 있는 최신 펌웨어와 기기가 가지고 있는 펌웨어 버전이 상이하면, 모바일 앱 블루투스 메인화면과 업데이트 화면에 펌웨어 업데이트 요청이 표시됩니다.

(단, 기기가 상위 버전인 경우에는 업데이트 요청이 표시되지 않습니다)

주의 사항

1. 최신 펌웨어 유지를 위해 모바일 앱을 항상 최신 상태로 업데이트하시기 바랍니다.
2. 스마트폰과 기기가 블루투스 연결이 되어 있어야만 기능을 수행할 수 있습니다.
3. 기기의 전원이 연결되어 있거나, 배터리 Level 3 이상에서만 다운로드 동작합니다.
4. 다운로드 및 업데이트 중 기기의 전원 종료 혹은 전원 케이블을 빼지 마시기 바랍니다.



배터리 충전 단계 안내

배터리 충전상태는 0단계부터 4단계로 나누어집니다. 충전상태는 연결된 모바일앱에 표기되며 충전이 필요한 경우에는 기기가 시작할 때 음성 안내로 충전 경고음이 안내됩니다.



블루투스 충전상태 안내

| 레벨 | 블루투스 충전상태 | 음성 안내 |
|------|-----------|-----------|
| 0 단계 | 충전 경고 | BT 로우 배터리 |
| 1 단계 | 정상 | - |
| 2 단계 | 완전 충전 | - |
| 3 단계 | | |
| 4 단계 | | |

전화 기능 & 볼륨 조정기능 사용하기

| 모드 | 키 동작 | 블루투스 LED | 음성 안내 | 비프음 |
|--------------|------------|----------|-------|-------|
| 전화벨 울림 | - | /// 점멸 | - | - |
| 전화 받기 | 중앙 (한번 누름) | /// | - | 뽁 x 1 |
| 전화 거절 | 중앙 (두번 누름) | /// | - | 뽁 x 1 |
| 전화 끊기 [통화 중] | 중앙 (두번 누름) | /// | - | 뽁 x 1 |
| 헤드셋 볼륨업 | ▲ (한번 누름) | | - | 뽁 x 1 |
| 헤드셋 볼륨다운 | ▼ (한번 누름) | | - | 뽁 x 1 |

볼륨업(한번 누름) 볼륨다운(한번 누름)

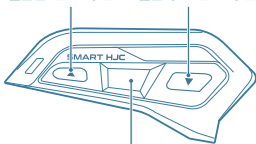

전화받기(한번 누름)
전화거절(두번 누름)
전화끊기(두번 누름)

음악 재생 (1초간 누름)
음악 멈춤 (1초간 누름)

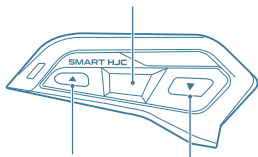

다음곡 (1초간 누름) 이전곡 (1초간 누름)

음악 듣기 기능 사용하기

| 모드 | 키 동작 | 블루투스 LED | 음성 안내 | 비프음 |
|-------|-------------|----------|-------|-------|
| 음악 재생 | 중앙 (1초간 누름) | /// | - | 뽁 x 1 |
| 음악 멈춤 | 중앙 (1초간 누름) | /// | - | 뽁 x 1 |
| 다음 곡 | ▲ (1초간 누름) | /// | - | 뽁 x 1 |
| 이전 곡 | ▼ (1초간 누름) | /// | - | 뽁 x 1 |

블루투스 세팅에서 폰 페어링 시작하기

폰 페어링과 인터콤 페어링은 블루투스 세팅 모드에서 설정할 수 있습니다.

블루투스 세팅 시작 / 종료하기

▼ 다운 버튼과 중앙 버튼을 동시에 1초 동안 누르면 “블루투스 모드”에 진입합니다.

1. 블루투스 세팅 모드 중 [중앙 버튼]을 두번 누르면 모드가 중단됩니다.
2. 페어링 세팅이 완료되면, 자동으로 블루투스 세팅 모드는 종료됩니다.
3. 블루투스 세팅 모드에서 페어링 세팅이 완료되지 않을 경우 10초 후 자동 종료됩니다.

블루투스 세팅 모드에서 폰 페어링 하기

블루투스 세팅 모드에서 ▼ 다운 버튼을 한번 누르면 새로운 “폰 페어링”이 시작됩니다.

기존 폰 페어링은 리셋이 되고, 안내방송과 LED로 상태가 표시됩니다. (아래 페어링 상태표 참조)

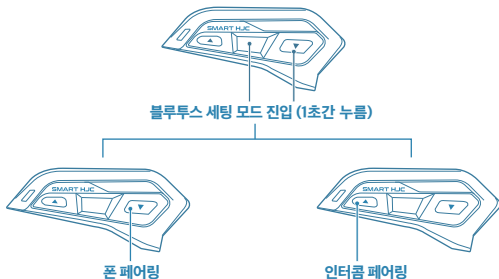

| 모드 | 키 동작 | 블루투스 LED | 음성 안내 | 비프음 |
|------------|---------------|----------|---------|-------|
| 블루투스 세팅 모드 | ▼+중앙 (1초간 누름) | /// | BT 세팅 | 뽁 x 1 |
| 블루투스 세팅 아웃 | 중앙 (두번 누름) | // | - | 뽁 x 2 |
| 폰 페어링 | ▼ (한번 누름) | // 순환 점멸 | 폰 페어링 | - |
| 인터콤 페어링* | ▲ (한번 누름) | // 순환 점멸 | 인터콤 페어링 | - |
| 폰 페어링 취소 | ▼ (두번 누름) | // | 페어링 취소 | - |
| 인터콤 페어링 취소 | ▲ (두번 누름) | // | 페어링 취소 | - |

인터콤 페어링* : 페어링 된 친구와 인터콤 연결 및 사용하는 방법은 20페이지에 있습니다.

블루투스 세팅에서 인터콤 페어링 시작하기

블루투스 세팅 모드에서 인터콤 페어링 시작하기

나와 친구 기기가 함께 페어링 동작을 시작하면, 기기는 자동으로 페어링 연결됩니다.
페어링 연결 후 자동으로 연결 상태로 진입하여 인터콤 통화가 가능합니다.

1. 블루투스 세팅에 진입합니다.
2. 블루투스 세팅에서 ▲ 업 버튼을 한번 누릅니다.
안내방송과 LED로 상태가 표시됩니다. (위 페어링 상태표 참조)
3. 기기는 친구 총 3명과 페어링을 연결할 수 있으며, 전원이 꺼져도 페어링 정보를 기억하고 있습니다.
4. 최초 페어링 친구가 등록된 상태에서 2번째 친구의 페어링을 등록하면,
최초 등록된 페어링 기기는 2번 기기, 2번째 등록한 친구가 1번 기기가 됩니다.
마찬가지로 3번째 친구가 페어링 등록되면, 3번째 등록한 친구는 1번 기기가 되며,
2번째 등록한 친구는 2번, 1번째 등록한 친구는 3번 기기가 됩니다.

주의 사항

1. 인터콤 연결을 위해서는 가까운 거리에서 친구의 기기와 함께 아래의 동작을 함께 수행해야 합니다.
2. 인터콤 페어링은 최대 3명의 친구까지 등록이 되며, 인터콤 통신은 1:1 통신만 할 수 있습니다.

친구와 인터콤 연결하기

기기에 인터콤 페어링 등록된 친구는 기기 전원 온 / 오프와 상관없이 기기에 등록정보가 저장되어 있습니다. 전원을 켜고 등록된 친구와 아래 연결하기 순서로 사용하시면 됩니다.

페어링 1번 기기 인터콤 연결하기

1. 연결을 원하는 기기에서 [중앙 버튼]을 한번 누르면 인터콤 연결 상태로 진입합니다.
기기에서 발신음이 안내됩니다.
2. 인터콤 수신 기기는 수신음이 안내되며, 수신인은 중앙 버튼을 한번 누르면 인터콤 연결을 완료하고 통화를 진행합니다.
3. 인터콤 통화 진행 중에 [중앙 버튼]을 두번 누르면 인터콤 통화가 종료됩니다.

페어링 2번 기기 인터콤 연결하기

연결을 원하는 기기에서 [중앙 버튼]을 두번 누르면 인터콤 연결 상태로 진입합니다.
기기의 진행 방법은 1번 기기 인터콤 연결하기와 동일합니다.

페어링 3번 기기 인터콤 연결하기

연결을 원하는 기기에서 [중앙 버튼]을 세번 누르면 인터콤 연결 상태로 진입합니다.
기기의 진행 방법은 1번 기기 인터콤 연결하기와 동일합니다.

마지막 페어링 연결된 기기가 1번 기기이며, 역순으로 연결정보가 저장됩니다.

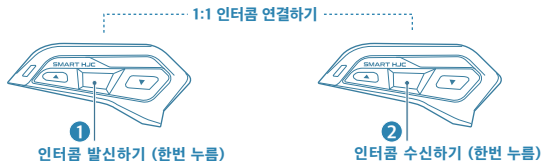

SMART HJC 다른 기기와 인터콤 연결하기

SMART HJC (50B / 21B / 11B) 제품의 설정을 유니버설 인터콤 페어링 모드로 전환하면, (11Be) 제품과 인터콤 연결을 할 수 있습니다. 또한 SMART HJC (10B / 20B)와 SENA 제품의 유니버설 모드 설정을 통해 인터콤 연결을 할 수 있습니다.

주의 사항

비 SMART HJC 블루투스 헤드셋이 블루투스 HFP(Hands-Free Profile)를 지원하는 경우 연결이 가능합니다.

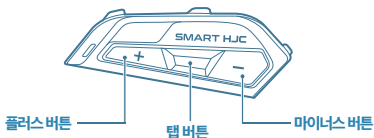

SMART HJC (50B / 21B / 11B) UI부

SMART HJC (50B / 21B / 11B) 유니버설 인터콤 페어링 모드 실행하기

1. 탭 버튼을 10초간 길게 누르기 [설정 메뉴 안내방송이 나옵니다.]
2. 마이너스 버튼을 3회 눌러주세요 [유니버설 인터콤 페어링 안내방송이 나옵니다.]
3. 탭 버튼을 1회 눌러주세요 [유니버설 인터콤 페어링 모드에 진입됩니다.]

SMART HJC (11Be) 인터콤 페어링 모드 실행하기

1. 중앙 버튼과 ▼ 다운 버튼을 동시에 눌러 "블루투스 세팅" 모드에 진입합니다.
2. "블루투스 세팅" 모드에서 ▲ 업 버튼을 눌러 인터콤 페어링 모드에 진입합니다.

SMART HJC (50B / 21B / 11B) 와 (11Be) 의 기기가 모두 페어링 모드에 진입되면 자동으로 인터콤 연결이 되어 통화가 가능합니다.



SMART HJC (11Be) UI부

스마트폰 모바일앱 다운로드하기

전용 모바일앱 다운로드하기

안드로이드폰은 “구글플레이스토어” 혹은 아이폰은 “앱스토어”에서 “SMART HJC BT (11BC/11Be)”를 검색하거나, 아래의 QR코드를 통해 모바일앱을 다운로드합니다.



Android AOS
구글플레이스토어



Apple IOS
앱스토어



모바일앱 OTA(Over-The-Air)

1. 블루투스 OTA 기능을 통해, 최신 펌웨어를 다운로드하실 수 있습니다.
2. 블루투스 OTA 기능을 통해, 다국어 언어 펌웨어를 다운로드하실 수 있습니다.

주의 사항

지속적인 품질 향상을 위해, 사전 고지 없이 기기 성능 개선 및 기능 업데이트가 이루어질 수 있습니다.

모바일앱 시작하기 1

1. 앱스토어에서 모바일 앱을 다운로드 후 설치해 주세요.
2. 스마트폰 블루투스 설정에서 기기와 페어링 해주세요.
3. 설치된 앱 아이콘을 터치해 앱을 실행해 주세요.
4. 앱 실행 중 페어링 팝업이 나타나면, "페어링"을 선택해 블루투스 기기와 연결해 주세요.

주의 사항

1. IOS(Apple) 사용자는 앱과 블루투스 기기 연결에 실패할 경우, 앱 대기화면의 '다시 연결하기' 버튼을 눌러 페어링을 다시 시도해 주세요.
2. AOS(Android) 사용자는 스마트폰 블루투스 설정에서 기기 페어링 완료 후, 앱 내 페어링 요청 팝업 없이 자동으로 블루투스 메인화면으로 이동합니다.



① 스마트폰 블루투스 설정
② 기기 연결(페어링)



③ 앱 실행 아이콘



④ 앱 대기화면

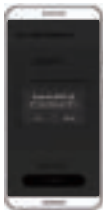

⑤ 기기 페어링 요청 팝업 화면



⑥ 블루투스 메인화면

모바일앱 시작하기 2



전원 시작

기기의 ▲(업) 버튼+중앙 버튼을 동시에 비프음이 나올 때까지 1.5초간 눌러주세요. “전원 시작” 음성 안내가 나오며, 기기가 시작됩니다.

전원 종료

기기의 전원이 켜진 상태에서 ▲(업) 버튼+중앙 버튼을 동시에 비프음이 나올 때까지 1.5초간 눌러주세요. “전원 종료” 음성 안내가 나오며, 기기가 종료됩니다.

자동 폰 페어링

기기를 최초 구매하고, 기기의 전원을 켜면 자동으로 폰 페어링 모드에 진입합니다. 스마트폰의 블루투스 설정에서 기기를 검색한 후 연결하세요. (폰 페어링 모드 중 ▼(다운) 버튼을 두번 누르면, 모드가 중단됩니다.)



블루투스 세팅 “폰 페어링”

STEP 1

전원을 켜 후, 중앙 버튼+▼(다운) 버튼을 동시에 1초간 눌러주세요. 비프음과 함께 블루투스 세팅 모드로 진입하며, “블루투스 세팅” 음성 안내가 시작됩니다.

STEP 2

블루투스 세팅 모드에서 ▼(다운) 버튼을 한번 누르면 “폰 페어링”이 시작됩니다. 기존 연결은 자동으로 해제되며, 새로 페어링 한 기기가 폰에 연결됩니다.

폰 페어링 취소

폰 페어링 모드에서 ▼(다운) 버튼을 두번 누르면 “페어링 취소” 모드로 전환됩니다. 이후 스마트폰의 블루투스 설정에서 기기를 다시 선택해 주세요.

모바일앱 시작하기 3



블루투스 세팅 “인터콤 페어링” [친구와 인터콤 연결하는 방법]

STEP 1

두 기기 모두 전원을 켜 후, 각자 중앙 버튼+▼(다운) 버튼을 동시에 1초간 눌러주세요. 비프음과 함께 블루투스 세팅 모드로 진입하면 각 기기에서 ▲(업) 버튼을 한번 눌러주세요. “인터콤 페어링” 음성 안내가 시작됩니다. 진행 중임을 알리는 비프음이 반복되며, 자동으로 상대방 기기를 검색합니다.

STEP 2

“인터콤 페어링” 음성 안내 후, 두 기기는 자동으로 인터콤 통신 상태로 연결됩니다.

인터콤 페어링 취소

인터콤 페어링 모드에서 ▲(업) 버튼을 두번 누르면 “페어링 취소” 모드로 전환됩니다.



인터콤 통화 시작 / 종료

최근 페어링 된 친구와 다시 통화하려면 중앙 버튼을 한번 누르세요.

양쪽 기기에서 비프음 “삐빅” 소리와 함께 자동으로 인터콤이 연결됩니다.

인터콤 통화 중에 수신인 또는 발신인 중 한 명이 중앙 버튼을 두번 누르면 인터콤 연결이 종료됩니다.

주의 사항

1. 인터콤은 최대 3명의 친구까지 등록할 수 있으며, 3명의 친구와 인터콤 하는 방법은 사용자 가이드 21페이지를 참고하시기 바랍니다.
2. 인터콤 친구 등록은 두 기기가 서로 가까운 거리에서 진행해야 정상 등록됩니다.

기능 모드 선택 화면



① 블루투스 모드 선택하기

기기와 모바일앱 페어링이 완료된 후 블루투스 메인화면으로 진입하는 버튼

② 사용자 가이드

나의 제품 사용설명서를 볼 수 있습니다.

③ 빠른 시작 비디오

나의 기기를 헬멧에 장착하는 영상을 볼 수 있습니다.

블루투스 메인 화면



① 배터리 레벨 상태 표시

② 블루투스 충전상태

③ 모델명

④ 최신 펌웨어 확인하기

기기의 펌웨어가 최신 상태가 아닐 경우, 붉은색 경고 문구가 표시됩니다.

⑤ 홈 화면

기능 모드 선택 화면으로 이동합니다.

⑥ 페어링 상태 화면

블루투스와 인터콤 페어링 상태를 확인할 수 있으며, 페어링 등록된 기기의 이름을 수정할 수 있습니다.

⑦ 블루투스 오디오 세팅 화면

블루투스 오디오 설정을 변경할 수 있습니다.

⑧ 블루투스 OTA 업데이트 화면

블루투스 펌웨어 업데이트와 기기의 음성 안내 언어를 변경 및 업데이트할 수 있습니다.

페어링 상태 화면

① 내 기기와 연결된 휴대폰 목록

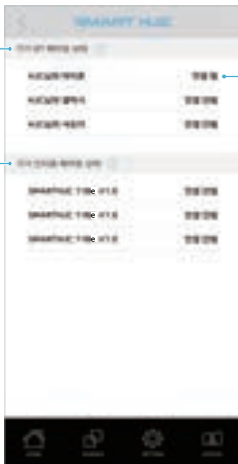

상태 표시

② 내 기기와 연결된 인터콤 목록

① 내 기기와 연결된 휴대폰 목록 (블루투스 페어링 상태)

현재 내 기기와 블루투스로 연결된 휴대폰 리스트가 표시됩니다.
최초 연결 시에는 폰의 블루투스 고유번호가 표시되며,
해당 번호를 탭 하면 이름 변경이 가능하여 기기 식별이 쉬워집니다.

② 내 기기와 연결된 인터콤 목록 (인터콤 페어링 상태)

현재 내 기기와 연결된 인터콤 기기 리스트가 표시됩니다.
최초 연결 시에는 기기의 블루투스 고유번호가 표시되며,
해당 번호를 탭 하면 이름 변경이 가능하여 기기 식별이 쉬워집니다.

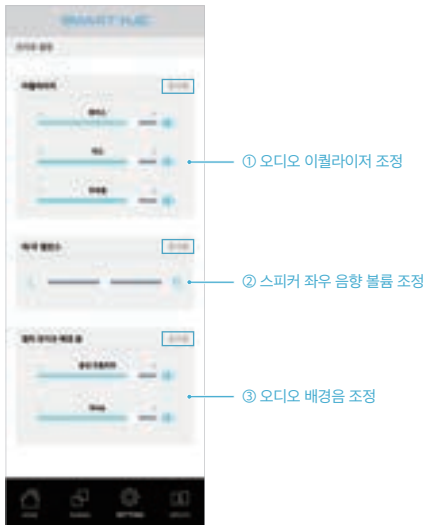

주의 사항

1. 기기에서 오디오를 조정한 후 전원을 껐다가 다시 켜도, 설정된 값은 그대로 유지됩니다.
2. 초기화를 선택하면 기기의 모든 설정이 출고 당시 상태로 되돌아갑니다.

블루투스 업데이트



① 블루투스 펌웨어 업데이트가 필요한 상태

모바일앱이 기기와 연결되면, 앱이 자동으로 업데이트 필요 여부를 확인하고 알림을 제공합니다.

② 블루투스 최신 펌웨어 상태

기기가 최신 펌웨어를 사용 중이면, 앱에서 “장치의 펌웨어가 최신 버전입니다”로 표시되어 별도 업데이트 없이 사용 가능합니다.

③ 기기의 음성 안내 언어를 다운로드하여 변경합니다.

기기는 출고 시 영어 음성 안내로 설정되어 있습니다. 모바일 앱을 통해 원하는 언어를 선택하고 다운로드하여, 기기의 음성 안내 언어를 손쉽게 변경할 수 있습니다.

주의 사항

1. 모바일 앱을 항상 최신 버전으로 유지해 주세요.
최신 앱은 기기의 펌웨어를 안정적으로 관리하고 업데이트합니다.
2. 기기 배터리가 충분하지 않으면 업데이트가 진행되지 않습니다.
업데이트 전, 배터리 잔량을 확인해 주세요.
3. 업데이트 중에는 전원 케이블을 절대 분리하지 마세요.
전원 연결이 끊기면 기기 오류가 발생할 수 있습니다.
4. 펌웨어 또는 음성 안내 언어 업데이트 완료 후, 기기는 자동으로 리셋됩니다.

한국어

SMART HJC 11Be

KC 인증정보



인증번호 : R-R-M2v-11Be

기자재명칭 : Bluetooth for motorcycle helmets

모델명 : 11Be

제조사/제조국가 : 엠텍비전 주식회사 / 한국

판매원 : (주)에이치제이씨(HJC Corporation)

국내외 인증 정보



CE
(유럽)



UKCA
(영국)



FCC
(미국)



IC
(캐나다)



KC
(한국)

HJC Corporation

HJC Bldg, 1002, Yangjae-daero, Songpa-gu,
Seoul, 05708 Seoul, Republic of Korea
www.hjchelmets.com



HJC Europe

1 Rue BENJAMIN SILLIMAN JR, 67116
REICHSSTETT, FRANCE

Manufacturer

엠텍비전 주식회사
경기도 성남시 수정구 창업로 42, 333호
www.mtekvision.com